

ENGINE DATA

 **TEKSAN**

 **Perkins**[®]

THE HEART OF EVERY GREAT MACHINE

2506C-E15TAG4



2506C-E15TAG3 2506C-E15TAG4

2500

Series

568 kWm (gross) @ 1800 rpm
623 kWm (gross) @ 1800 rpm

Diesel Engine - ElectropaK

Basic technical data

Number of cylinders	6
Cylinder arrangement	Vertical Inline
Cycle	4 stroke
Induction system	Turbocharged, air-to-air chargecooling
Combustion system	Direct Injection
Compression ratio	16:1
Bore	137 mm
Stroke	171 mm
Cubic capacity	15.2 litres
Direction of rotation	Anti clockwise when viewed from flywheel
Firing order (number 1 cylinder furthest from flywheel)	1, 5, 3, 6, 2, 4

Total weight of ElectropaK

Estimated total weight (dry)	1633 kg
Estimated total weight (wet)	1714 kg

Overall dimensions, ElectropaK

Height	1718 mm
Length (air cleaner fitted)	2657 mm
Width	1120 mm

Moments of inertia (mk²)

Engine	2.3291 kgm ²
Flywheel	1.96355 kgm ²

Cyclic irregularity

Engine/flywheel maximum	1:60
-------------------------------	------

Performance

Note: All data based on operation to ISO 3046/1, BS5514 and DIN 6271

Note: standard reference conditions.

Ratings

Electrical ratings are based on average alternator efficiency and are for guidance only (0.8 power factor being used).

Steady state stability at constant speed

± 0.25%

Sound level

Estimated sound pressure at 1 metre	105.2 dB(A)
---	-------------

Operating point

Engine speed	1800 rpm
Cooling water maximum exit temperature	< 107°C

Test conditions

Air temperature	25°C
Barometric pressure	100 kPa
Relative humidity	30%
Exhaust back pressure at maximum power (nominal)	6,0 kPa
Fuel temperature (inlet pump)	40°C

Note: If the engine is to operate in ambient conditions other than those of the test conditions, suitable adjustments must be made for these changes. For full details, contact Perkins Technical Service Department.

For test conditions relevant to data on load acceptance, refer to the bottom of page 14.

General installation

Designation	Units	Type of operation and application		
		2506C-E15TAG3		2506C-E15TAG4
		80 Hz @ 1800 rpm		80 Hz @ 1800 rpm
		Prime power	Standby	Standby
Gross engine power	kWb	534	587	623
Fan power	kWm	15.5		15.5
Restriction losses	kWm	9.1	10.0	10.5
Electropak nett engine power	kWm	509	562	597
Gross brake mean effective pressure	kPa	2341	2575	2769
Combustion air flow	m ³ /min	39	42	42
Exhaust gas temperature after turbo (maximum)	°C	N/A	550	550
Exhaust gas flow	kg/s	102	112	120
Boost pressure ratio		3.3	3.5	3.5
Overall thermal efficiency (nett)	%	39.1	40.1	40
Friction and pumping power losses	kWm	57		62
Mean piston speed	m/s	10		10
Engine coolant flow	l/sec	7.2		7.2
Cooling fan air flow (zero duct allowance)	m ³ /min	866		866
Typical generator set electrical output (0.8 pf)	kWe	468	517	550
	kVA	585	646	687
Assumed alternator efficiency	%	92		92

Note: Emergency Standby Power only - power available in the event of a main power network failure, up to a maximum of 200 hours per year which may be run continuously. Load factor may be up to 100% of the Emergency Standby Power rating. No overload is permitted.

Rating definitions

Prime power

Variable load. Unlimited hours usage with an average load factor of 80% of the published Prime Power rating over each 24 hour period. A 10% overload is available for 1 hour in every 12 hours operation.

Standby power

Variable load. Limited to 500 hours annual usage up to 300 hours of which may be continuous running. No overload is permitted.

Emissions capability

Certified against the requirements of Tier 2 legislation for non-road mobile machinery, powered by constant speed engines (EPA 40 CFR Part 89 Tier 2). These engines also comply with the 1/2 TA Luft (1986) NOx limits of 2000 mg/m³

Energy balance

Designation	Units	Type of operation and application		
		2506C-E15TAG3		2506C-E15TAG4
		80 Hz @ 1800 rpm		80 Hz @ 1800 rpm
		Prime power	Standby	Standby
Energy in fuel	kWt	1365	1464	1540
Energy in power output (gross)	kWb	534	587	623
Energy to cooling fan and restrictions	kWm	24.6	25.5	26
Energy in power output (nett)	kWm	509	562	597
Energy to exhaust	kWt	486	509	540
Energy to coolant and oil	kWt	175	188	195
Energy to radiation	kWt	51	54	26.5
Energy to chargecooler	kWt	120	125	140

2506C-E15TAG4



Cooling system

Recommended coolant

50% Inhibited ethylene glycol or 50% Inhibited propylene glycol and 50% clean fresh water. Where there is no likelihood of ambient temperatures below 10°C, clean soft water may be used, treated with 1% by volume of Perkins inhibitor in the cooling system. The inhibitor is available from all Perkins distributors.

Total system coolant capacity	58.0 litres
Maximum pressure in crankcase water jacket	276 kPa
Maximum top tank temperature	107°C
Maximum static pressure on pump	170 kPa
Maximum permissible restriction to coolant pump flow	30 kPa

Temperature rise across engine with inhibited coolant	
Standby power	10°C
Prime power	9°C
Thermostat operation range	88 to 98°C

Radiator

Face area	1,238 m ²
Weight (dry)	132 kg
Number of rows and materials	2 rows, Aluminium
Matrix density and material	12 fins per inch, Aluminium
Width of matrix	1048 mm
Height of matrix	1100 mm
Pressure cap setting (minimum)	69 kPa

Chargecooler with integral radiator

Face area	1,006 m ²
Number of rows and materials	1 row, Aluminium
Matrix density and material	12.5 fins per inch, Aluminium
Width of matrix	915 mm
Height of matrix	1100 mm

Coolant pump

Speed @ 1500 rpm	1946 rpm
Drive method	Gear

Fan

Diameter	927 mm
Drive ratio	0.92:1
Number of blades	9
Material	B3WG6 or PA6GF30 Nylon 6 glass filled 30%
Type	ACS 367500

Exhaust system

Maximum back pressure - 1500 rpm	6.8 kPa
Exhaust outlet, internal diameter	127 mm

Recommended exhaust pipe diameter

Length	mm
Up to 10 m	150
10 m to 20 m	150
20 m to 30 m	200

Cooling clearance

Ambient cooling clearance (standby power) based on air temperature at fan of 6°C above the ambient

2506C-E15TAG3 and 2506C-E15TAG4 maximum additional restriction (duct allowance) to cooling airflow and resultant minimum airflow			
Duct allowance with 60% glycol at 60°C			
Description	rpm	Units	Standby
Duct allowance	1800	KPa	0.125
Minimum airflow	1800	m ³ /min	822
Duct allowance with 60% glycol at 43°C			
Duct allowance	1800	KPa	0.200
Minimum airflow	1800	m ³ /min	792

Electrical system

Type	12 volts negative earth
Alternator type	22 SI
Alternator voltage	24 volts
Alternator output	70 amps
Starter motor type	42 MT
Starter motor voltage	24 volts
Starter motor power	7.5 kW
Number of teeth on the flywheel	113
Number of teeth on starter pinion	11
Minimum cranking speed	100 rpm
Starter solenoid maximum ⁽¹⁾	
Pull-in current @ -25°C	57 amps
Hold-in current @ -25°C	16 amps

1. All leads to rated at 10 amps minimum.

Cold start recommendations

Temperature range	5 to -10°C	-11 to -25°C
SAE grade Oil	15W40	0W40
Starter	42MT	
Battery	2x 12V 128 Ah	
Maximum breakaway current	1250 amps	
Cranking current	676 amps	880 amps
Starting Aids (ECM controlled)	None	Block heater 1.5 kW
Minimum mean cranking speed	120 rpm	

Notes:

- battery capacity is defined by the 20 hour rate
- the oil specification should be for the minimum ambient temperature as the oil will not be warmed by the immersion heater
- breakaway current is dependent on battery capacity available. Cables should be capable of handling the transient current which may be up to double the steady cranking current

Mountings

Maximum static bending moment at rear face of block... 1356 Nm

Engine management system

Full electronic engine management system controlling:

- speed governing
- air/fuel ratio
- start/stop sequence
- engine protection and diagnostics

2506C-E15TAG4



Fuel system

Injection system	MEUI
Injector type	MEUI
Injector pressure	200 MPa

Fuel lift pump

Type	Gear driven
Delivery flow	457 litres/hour
Pressure	550 kPa
Maximum suction head at pump inlet	3 m
Maximum static pressure head	4 m
Fuel Inlet temperature to be less than	55°C
Governor type	Electronic
Governing to	ISO 8528-5 class G3 steady state

Fuel filtration level

Primary	10 µm
Secondary	2 µm

Fuel consumption

Designation	Fuel consumption calculated on nett rated powers	
	2506C-E15TAG4 1500 rpm	
	g/kWh	litres/hour
Standby	210.0	132.0
Prime + 10%	210.0	132.0
Prime	211.0	121.0
75% Prime power	223.0	96.0
50% Prime power	268.5	77.0

Designation	Fuel consumption calculated on nett rated powers	
	2506C-E15TAG4 1500 rpm	
	g/kWh	litres/hour
Standby	211	146

Induction system

Maximum air intake restriction

Clean filter	3.7 kPa
Dirty filter	6.2 kPa
Air filter type	Paper element - 457 mm diameter

Lubrication system

The recommended SAE viscosity is a multigrade oil (15W40) which adequately meets the specifications of API C14

Total system capacity	60.0 litres
Maximum sump capacity	53.0 litres
Minimum sump capacity	45.0 litres
Lubricating oil pressure, at rated speed	420 kPa
Nominal (minimum)	200 kPa
Oil relief valve opens (with pressure difference of)	255 ± 20 kPa
Oil filter screen spacing	30 µm
Sump drain plug tapping size	M24
Oil pump speed and drive method	1.16 x engine speed, gear
Oil flow	3.4 litres/second
Oil consumption at full load rated speed	0.1%
Oil temperature (In rail) maximum continuous operation	114°C

Normal operating angles

Front and rear	7°
Side tilt	7°

Recommended SAE viscosity

A single or multigrade oil must be used which conforms to API C14 or ACEA E5.

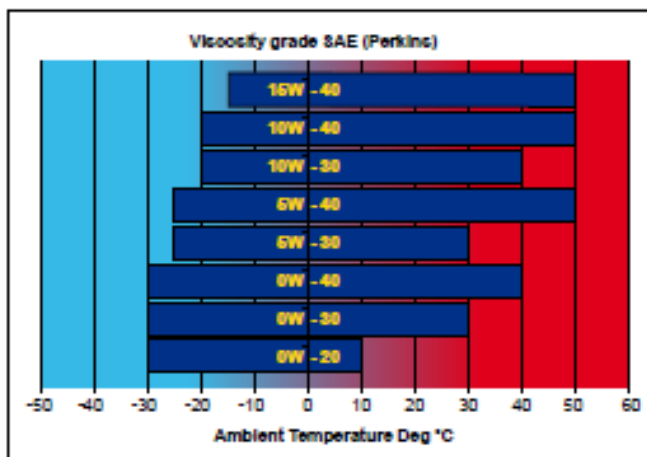

Typical load acceptance

The below figures were obtained under test conditions as follows:

Engine block temperature	45°C
Ambient temperature	15°C
Governing mode	Isochronous
Alternator Inertia	8 kgm ²
Under frequency roll off (UFRO) point set to	1 Hz below rated frequency
UFRO rate set to	2% voltage/1% frequency
LAM on/off	Off

All tests were conducted using an engine installed and serviced to Perkins Engines Company Limited recommendations.

2506C-E15 Initial load acceptance when engine reaches rated speed (15 seconds maximum after engine starts to crank)

Description	Units	TAG3	TAG4
		1800 rpm	
% of Prime power	%	60	55
Load (nett)	kWm	273	275
Transient frequency deviation	%	≤10	
Frequency recovery time	Seconds	5	

2506C-E15 2nd load acceptance when engine reaches rated speed (5 seconds maximum after engine starts to crank)

Description	Units	TAG3	TAG4
		1800 rpm	
% of Prime power	%	55	50
Load (nett)	kWm	250	
Transient frequency deviation	%	≤10	
Frequency recovery time	Seconds	5	

Note:

- the applied load is a percentage of generator electrical output, using alternator efficiencies as published in the general installation section of this Technical Data Sheet
- the information given on this Technical Data Sheet is for standard ratings only. For ratings other than those shown, please contact Perkins Engines Company Limited, Stafford
- the information given in this document is for guidance only

2506C-E15TAG3 and 2506C-E15TAG4 - left side view

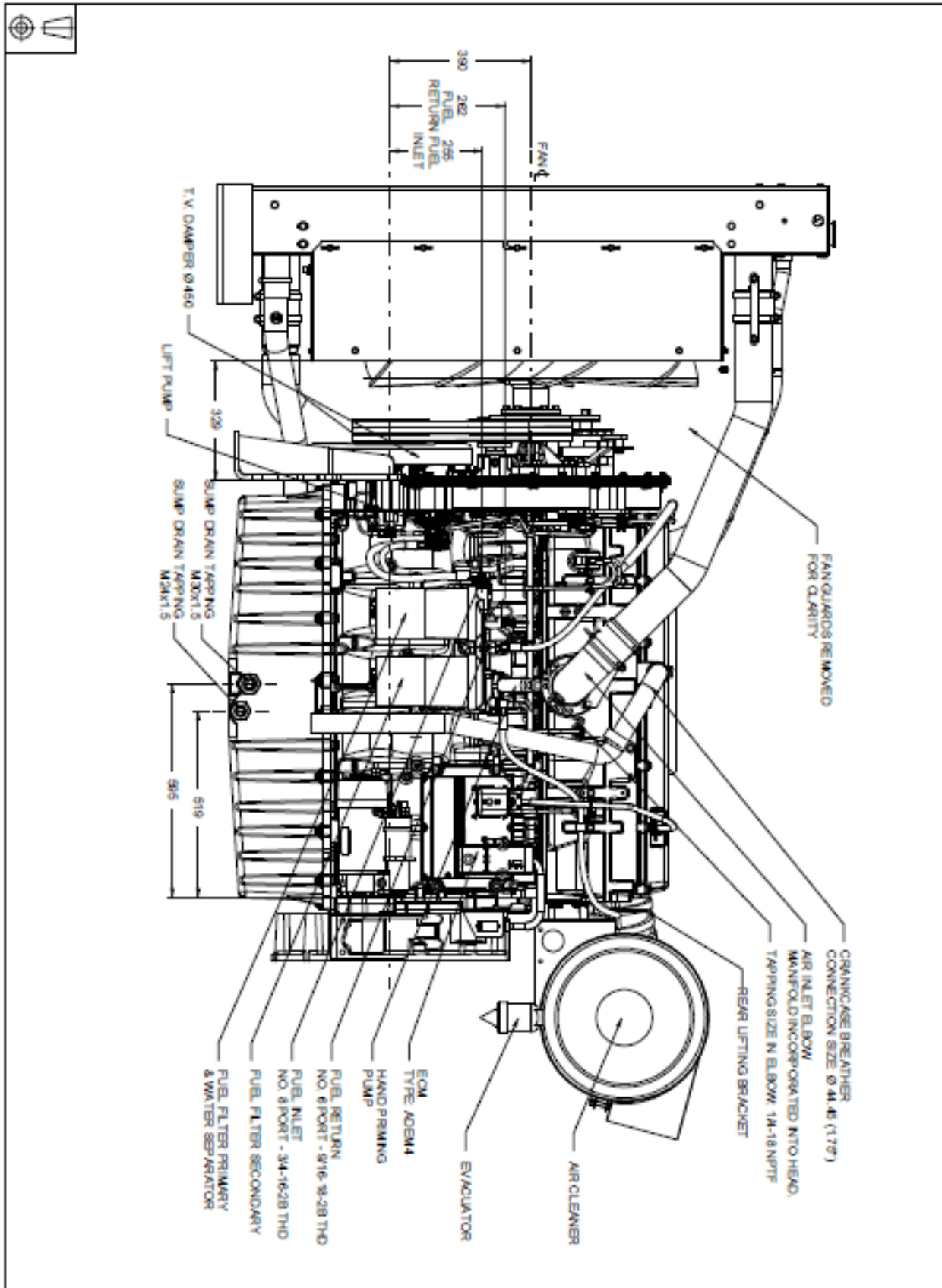

2506C-E15TAG3 and 2506C-E15TAG4 - front view

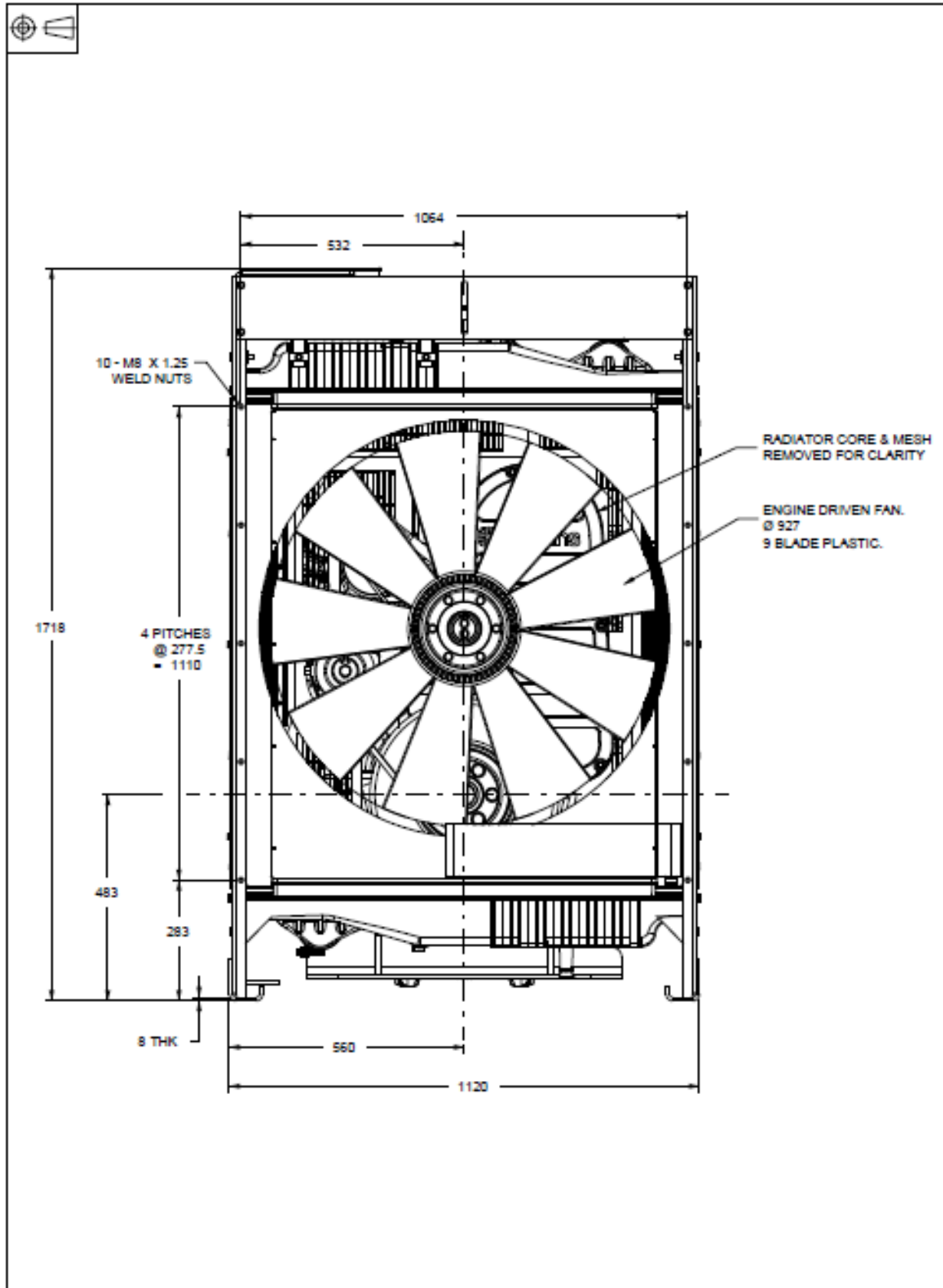

2506C-E15TAG3 and 2506C-E15TAG4 - right side view

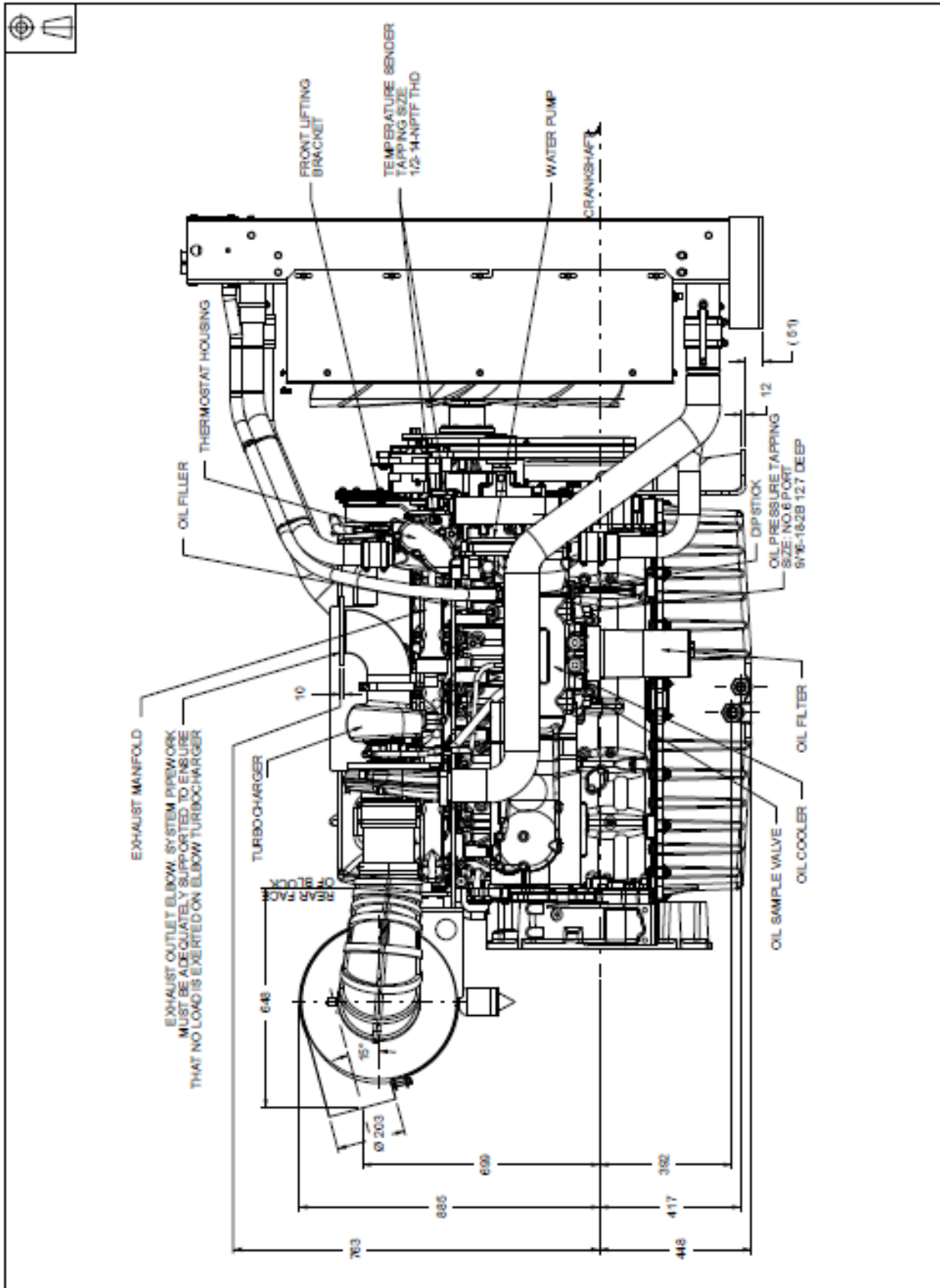

2506C-E15TAG3 and 2506C-E15TAG4 - rear view

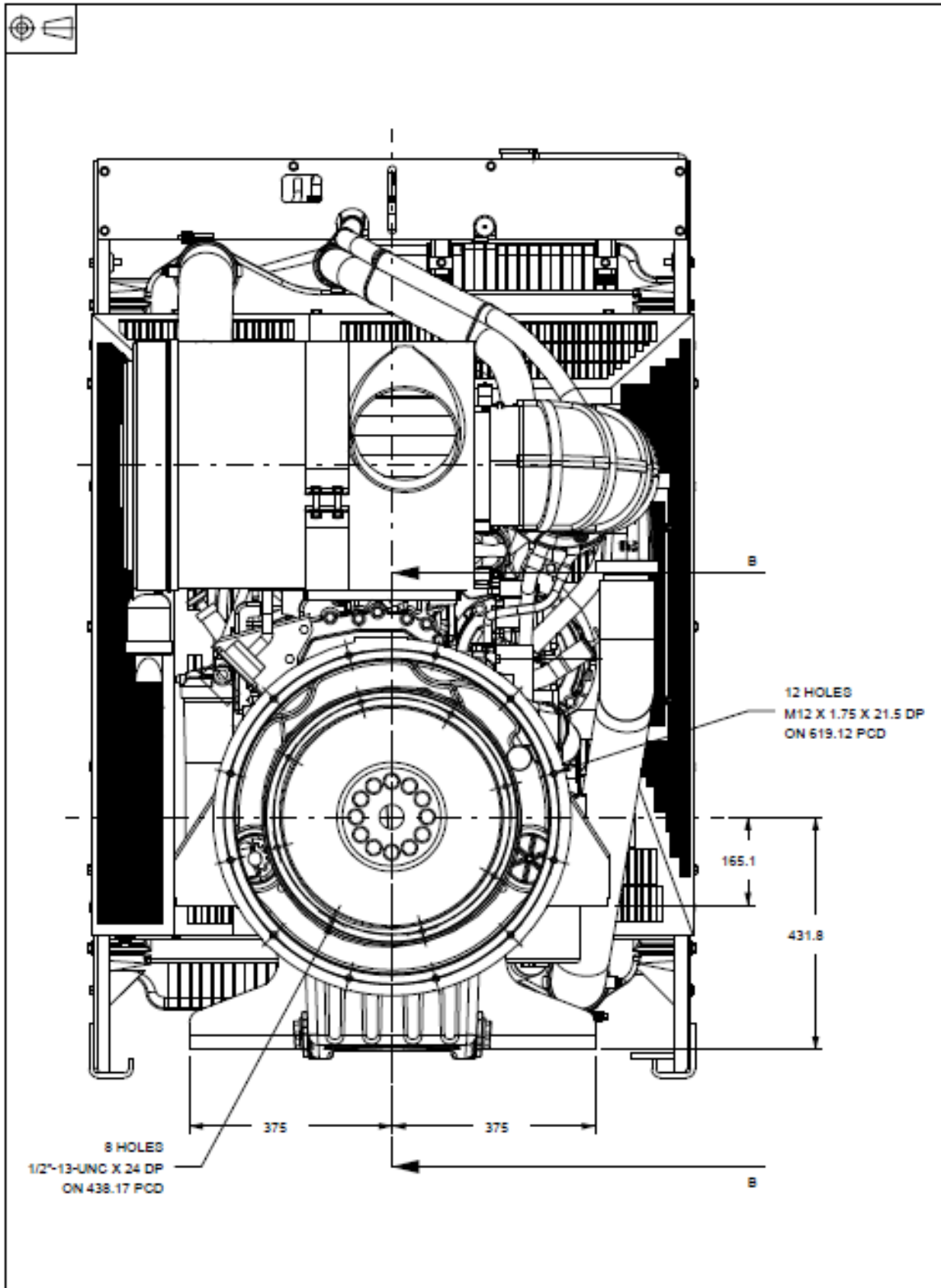

2506C-E15TAG3 and 2506C-E15TAG4 - plan view

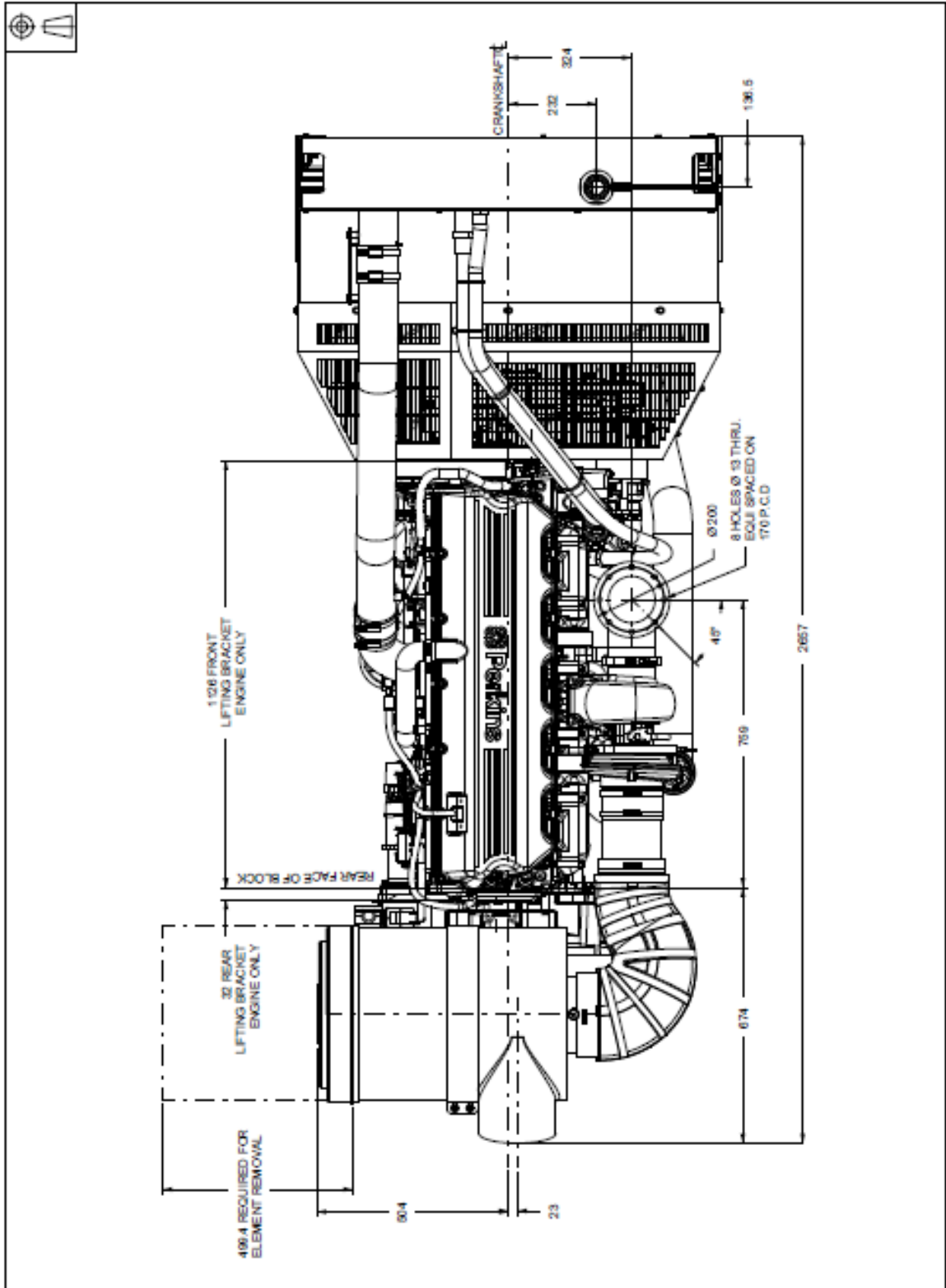

2506C-E15TAG3 and 2506C-E15TAG4 - miscellaneous views

