

ENGINE DATASHEET



2500 Series 2506C-E15TAG3 Diesel Engine – ElectropaK

543 kWm at 1800 rpm

The 2500 Series engine has been developed using the latest engineering techniques and builds on the strengths of the already very successful 2000 Series family and addresses today's uncompromising demands within the power generation industry. Developed from a proven heavy-duty industrial base these products offer superior performance and reliability.

The 2506C-E15TAG3 is a turbocharged and air-to-air charge-cooled, 6 cylinder diesel engine. Its premium features provide economic and durable standby duty, exceptional power-to-weight ratio resulting in exceptional fuel consumption and low gaseous emissions and advanced overall performance and reliability making this the prime choice for today's power generation industry.

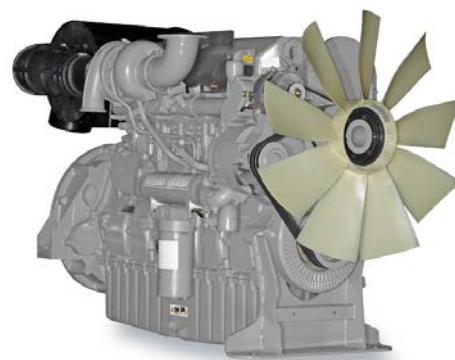

Specification		
Number of cylinders	6 vertical in-line	
Bore and stroke	137 x 171 mm	5.4 x 6.7 in
Displacement	15.2 litres	927 in ³
Aspiration	Turbocharged and air-to-air charge cooled	
Cycle	4 stroke	
Combustion system	Direct injection	
Compression ratio	16:1	
Rotation	Anti-clockwise, viewed on flywheel	
Total lubricating capacity	62 litres	16.4 US gal
Cooling system	Water-cooled	
Total coolant capacity	58 litres	15.3 US gal

www.perkins.com

Photographs are for illustrative purposes only and may not reflect final specification. All information in this document is substantially correct at time of printing and may be altered subsequently. Final weight and dimensions will depend on completed specification.

Publication No. PN1847/12/14 Produced in England ©2014 Perkins Engines Company Limited

 **Perkins**[®]

THE HEART OF EVERY GREAT MACHINE

2500 Series 2506C-E15TAG3 Diesel Engine – Electropak

543 kWm at 1800 rpm

Features and benefits

Economic power

- Mechanically operated unit fuel injectors with advanced electronic control, combined with carefully matched turbocharging, give excellent fuel atomisation which leads to exceptional low fuel consumption

Reliable power

- Developed and tested using the latest engineering techniques and finite element analysis for high reliability
- Low oil usage and low wear rates
- High compression ratio ensures clean rapid starting in all conditions
- Perkins global product support is designed to enhance the customer experience of owning a Perkins powered machine. We deliver this through the quality of our distribution network, extensive global coverage and a range of Perkins supported OEM partnership options. So whether you are an end-user or an equipment manufacturer our engine expertise is essential to your success

Compact, clean and efficient power

- Exceptional power to weight ratio and compact size gives optimum power density for ease of installation and more cost effective transportation
- Designed to provide excellent service access for ease of maintenance

Product support

- Perkins actively pursues product support excellence by ensuring our distribution network invest in their territory – strengthening relationships and providing more value to you, our customer
- Through an experienced global network of distributors and dealers, fully trained engine experts deliver total service support around the clock, 365 days a year. They have a comprehensive suite of web based tools at their fingertips covering technical information, parts identification and ordering systems, all dedicated to maximising the productivity of your engine
- Throughout the entire life of a Perkins engine, we provide access to genuine OE specification parts and service. We give 100% reassurance that you receive the very best in terms of quality for lowest possible cost .. wherever your Perkins powered machine is operating in the world

Certified against the requirements of Tier 2 legislation for non-road mobile machinery, powered by constant speed engines (EPA 40 CFR Part 89 Tier 2)

www.perkins.com

Photographs are for illustrative purposes only and may not reflect final specification.
All information in this document is substantially correct at time of printing and may be altered subsequently.
Final weight and dimensions will depend on completed specification.

Publication No. PN1847/12/14 Produced in England ©2014 Perkins Engines Company Limited

 **Perkins**[®]

THE HEART OF EVERY GREAT MACHINE

2500 Series 2506C-E15TAG3 Diesel Engine – Electropak

543 kWm at 1800 rpm

Technical information

Air inlet

- Mounted air filter

Fuel system

- Mechanically actuated electronically controlled unit fuel injectors with full authority electronic control
- Governing to ISO 8528-5 class G3 with isochronous capability
- Replaceable 'Ecoplus' fuel filter elements with primary filter/water separator
- Fuel cooler

Lubrication system

- Wet sump with filler and dipstick
- Full-flow replaceable 'Ecoplus' filter
- Oil cooler integral with filter header

Cooling system

- Gear-driven circulating pump
- Mounted belt-driven fan
- Radiator supplied loose incorporating air-to-air charge cooler
- System designed for ambients up to 50°C

Electrical equipment

- 24 volt starter motor and 24 volt 70 amp alternator with DC output
- ECM mounted on engine with wiring looms and sensors
- 3 level engine protection system

Flywheel and housing

- High inertia flywheel to SAE J620 size 14
- SAE ½ flywheel housing

Mountings

- Front engine mounting bracket

Optional equipment

- 110 volt/240 volt immersion heater
- Additional speed sensor
- Temperature and pressure sensors for gauges
- Air filter rain hood
- Twin starters/facility for second starter
- Tool kit
- Additional manuals
- Closed circuit crankcase ventilation system

www.perkins.com

Photographs are for illustrative purposes only and may not reflect final specification.
All information in this document is substantially correct at time of printing and may be altered subsequently.
Final weight and dimensions will depend on completed specification.

Publication No. PN1847/12/14 Produced in England ©2014 Perkins Engines Company Limited

 **Perkins**[®]

THE HEART OF EVERY GREAT MACHINE

2500 Series 2506C-E15TAG3 Diesel Engine – Electropak

543 kWm at 1800 rpm

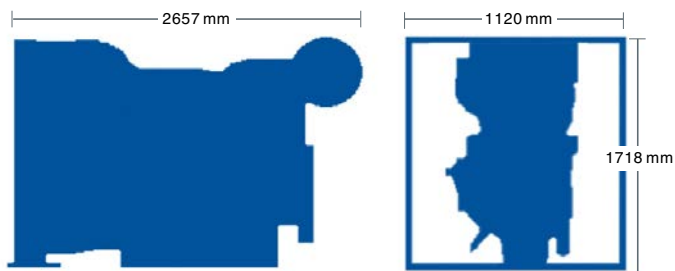

Engine package weights and dimensions		
Length	2657 mm	105 in
Width	1120 mm	44 in
Height	1718 mm	68 in
Weight (dry)	1633 kg	3600 lb

www.perkins.com

Photographs are for illustrative purposes only and may not reflect final specification.
All information in this document is substantially correct at time of printing and may be altered subsequently.
Final weight and dimensions will depend on completed specification.

Publication No. PN1847/12/14 Produced in England ©2014 Perkins Engines Company Limited

 **Perkins**[®]

THE HEART OF EVERY GREAT MACHINE

2500 Series 2506C-E15TAG3 Diesel Engine – Electropak

543 kWm at 1800 rpm

Speed rpm	Type of operation	Typical generator output (Net)		Engine power			
				Gross		Net	
		kVA	kWe	kWm	hp	kWm	hp
1800	Prime power	569	455	519	696	495	664
	Standby power	625	500	568	762	543	729

The above ratings represent the engine performance capabilities to conditions specified in ISO 8528/1, ISO 3046/1:1986, BS 5514/1. **Derating may be required for conditions outside these; consult Perkins Engines Company Limited.**

Generator powers are typical and are based on an average alternator efficiency and a power factor (cos. θ) of 0.8. **Fuel specification:** BS 2869: Part 2 1998 Class A2 or ASTM D975 D2. **Lubricating oil:** 15W40 to API CI4.

Rating definitions

Prime power: Power available at variable load with a load factor not exceeding 80% of the prime power rating. Overload of 10% is permitted for 1 hour in every 12 hours' operation. **Standby power:** Power available in the event of a main power network failure up to a maximum of 500 hours per year of which up to 300 hours may be run continuously. Load factor may be up to 100% of standby power. No overload is permitted.

Percent of prime power	Fuel consumption at 1800 rpm g/kWh	Fuel consumption at 1800 rpm l/hr
Standby power	210.0	132
Prime power	211.0	121
75%	223.0	96
50%	268.5	77

www.perkins.com

Photographs are for illustrative purposes only and may not reflect final specification. All information in this document is substantially correct at time of printing and may be altered subsequently. Final weight and dimensions will depend on completed specification.

Publication No. PN1847/12/14 Produced in England ©2014 Perkins Engines Company Limited



THE HEART OF EVERY GREAT MACHINE

Technical Data

2500 Series

2506C-E15TAG3

2506C-E15TAG4

Diesel Engine - ElectropaK

Basic technical data

Number of cylinders 6
 Cylinder arrangement..... Vertical, In-line
 Cycle 4 stroke
 Induction system turbocharged, air to air charge cooling
 Combustion system..... direct injection
 Compression ratio 16:1
 Bore 137 mm
 Stroke 171 mm
 Cubic capacity 15,2 litres
 Direction of rotation anti-clockwise viewed on flywheel
 Firing order (cylinder 1 furthest from flywheel) 1, 5, 3, 6, 2, 4

Total weight of ElectropaK

-dry (engine only) 1633 kg
 -wet..... 1714 kg

Overall dimensions

-height 1718 mm
 -length 2657 mm
 -width 1120 mm

Moments of inertia (mk²)

Engine 2.3291 kgm²
 Flywheel 1.96355 kgm²

Performance

Note: All data based on operation to ISO 3046/1, BS5514 and DIN 6271 standard reference conditions.

Cyclic irregularity

Engine / Flywheel maximum..... 1:60

Ratings

Steady state stability at constant speed ± 0,25 %
 Electrical ratings are based on average alternator efficiency and are for guidance only (0.8 power factor being used)

Operating point

Engine speed 1800 rev/min
 Cooling water maximum exit temperature < 107 °C

Fuel data

To conform to BS2869 class A2 or BS EN590

Test conditions

-air temperature 25 °C
 -barometric pressure 100 kPa
 -relative humidity 30%
 -air inlet restriction at maximum power (nominal)..... 2,5 kPa
 -exhaust back pressure at maximum power (nominal)..... 6,0 kPa
 -maximum fuel temperature (inlet pump)..... 40 °C

Note: If the engine is to operate in ambient conditions other than those of the test conditions, suitable adjustments must be made for these changes. For full details, contact Perkins Technical Service Department. For test conditions relevant to data on load acceptance, refer to the bottom of page 14.

Sound level

Estimated sound pressure level at 1 metre 105,2 dB(A)

General installation

2506C-E15TAG3

Designation	Units	Type of operation and application	
		Prime	Standby
		60 Hz @ 1800 rev/min	
Gross engine power	kWb	519	568
Fan power	kWm	15,5	
Restriction losses	kWm	8,9	9,5
ElectropaK nett engine power	kWm	495	543
Gross brake mean effective pressure	kPa	2307	2524
Combustion air flow	m³/min	39	42
Exhaust gas temperature (max)	°C	N/A	550
Exhaust gas flow	m³/min	102	112
Boost pressure ratio	-	3,3	3,5
Overall thermal efficiency (nett)	%	41,0	41,2
Friction and pumping power losses	kWm	57	
Mean piston speed	m/s	10	
Engine coolant flow	l/sec	7,2	
Cooling fan air flow (zero duct allowance)	m³/min	866	
Typical Gen Set electrical output (0.8 pf)	kWe	455	500
	kVA	569	625
Assumed alternator efficiency	%	92	

2506C-E15TAG4

Designation	Units	Type of operation and application
		Emergency Standby Power only
		60 Hz @ 1800 rev/min
Gross engine power	kWb	623
Fan power	kWm	15,5
Restriction losses	kWm	10,5
ElectropaK nett engine power	kWm	597
Gross brake mean effective pressure	kPa	2769
Combustion air flow	m³/min	42
Exhaust gas temperature (max)	°C	550
Exhaust gas flow	m³/min	120
Boost pressure ratio	-	3,5
Overall thermal efficiency (nett)	%	40
Friction and pumping power losses	kWm	62
Mean piston speed	m/s	10
Engine coolant flow	l/sec	7,2
Cooling fan air flow (zero duct allowance)	m³/min	866
Typical Gen Set electrical output (0.8 pf)	kWe	550
	kVA	687
Assumed alternator efficiency	%	92

Note: Emergency Standby Power only - power available in the event of a main power network failure, up to a maximum of 200 hours per year which may be run continuously. Load factor may be up to 100% of the Emergency Standby Power rating. No overload is permitted.

Rating definitions

Prime power

Variable load. Unlimited hours usage with an average load factor of 80% of the published Prime Power rating over each 24 hour period. A 10% overload is available for 1 hour in every 12 hours operation.

Standby power

Variable load. Limited to 500 hours annual usage up to 300 hours of which may be continuous running. No overload is permitted.

Emissions capability

Certified against the requirements of Tier 2 legislation for non-road mobile machinery, powered by constant speed engines (EPA 40 CFR Part 89 Tier 2). These engines also comply with the 1/2 TA Luft (1986) NOx limits of 2000 mg/nm³

Energy balance

2506C-E15TAG3

Designation	Units	Type of operation and application	
		Prime	Standby
		60 Hz @ 1800 rev/min	
Energy in fuel	kWt	1260	1380
Energy in power output (gross)	kWb	519	568
Energy to cooling fan and restrictions	kWm	24.4	25
Energy in power output (nett)	kWm	495	543
Energy to exhaust	kWt	395	450
Energy to coolant and oil	kWt	186	190
Energy to radiation	kWt	38,5	32,5
Energy to charge cooler	kWt	106	124

2506C-E15TAG4

Designation	Units	Type of operation and application	
		Emergency Standby Power only	
		60 Hz @ 1800 rev/min	
Energy in fuel	kWt	1540	
Energy in power output (gross)	kWb	623	
Energy to cooling fan and restrictions	kWm	26	
Energy in power output (nett)	kWm	597	
Energy to exhaust	kWt	540	
Energy to coolant and oil	kWt	195	
Energy to radiation	kWt	26,5	
Energy to charge cooler	kWt	140	

2506C-E15TAG3 and 2506C-E15TAG4 - left side view

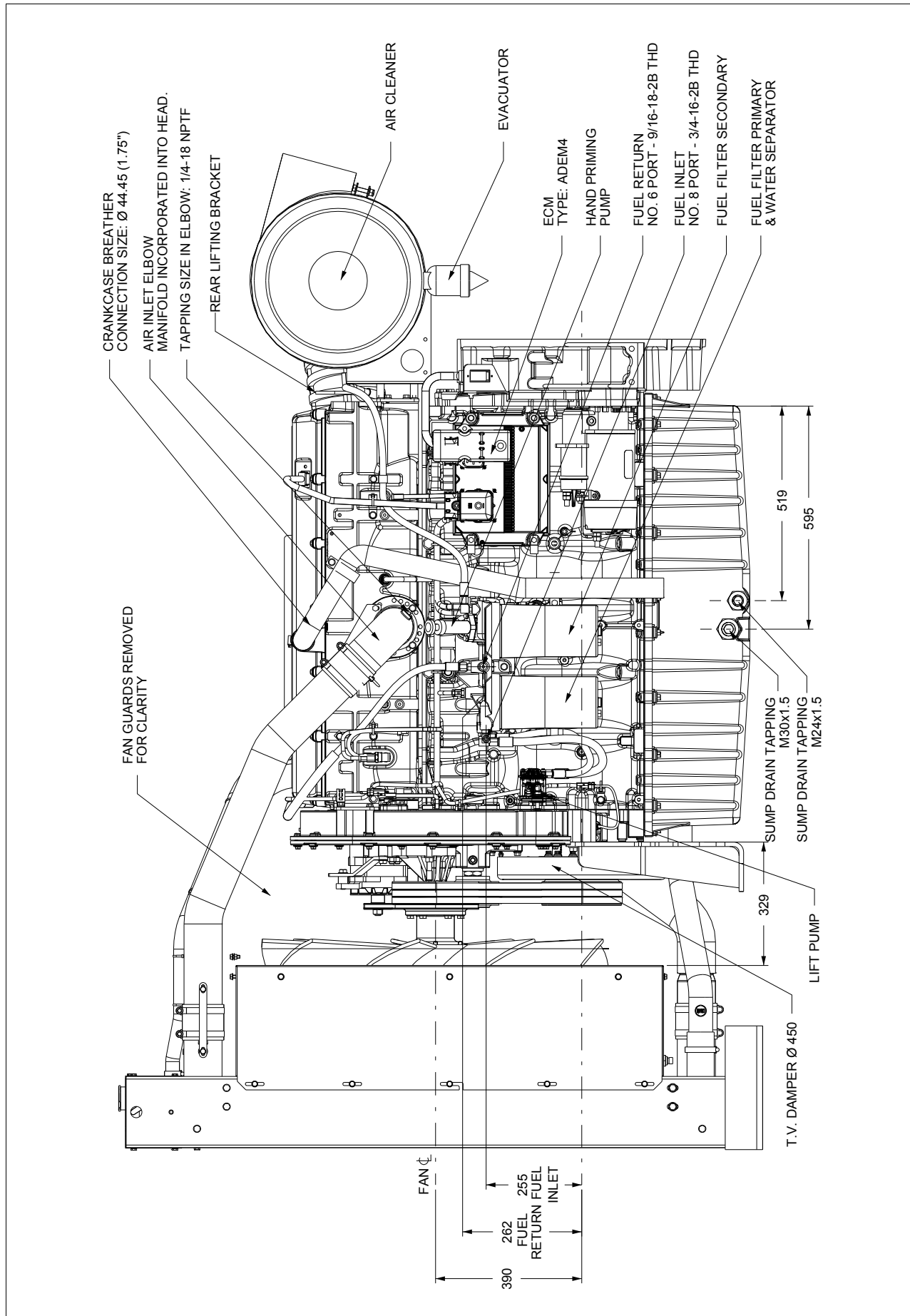

Note: This drawing is for reference only. For installation purposes, please refer to the relevant General Installation drawing (Z13579).

2506C-E15TAG3 and 2506C-E15TAG4 - front view

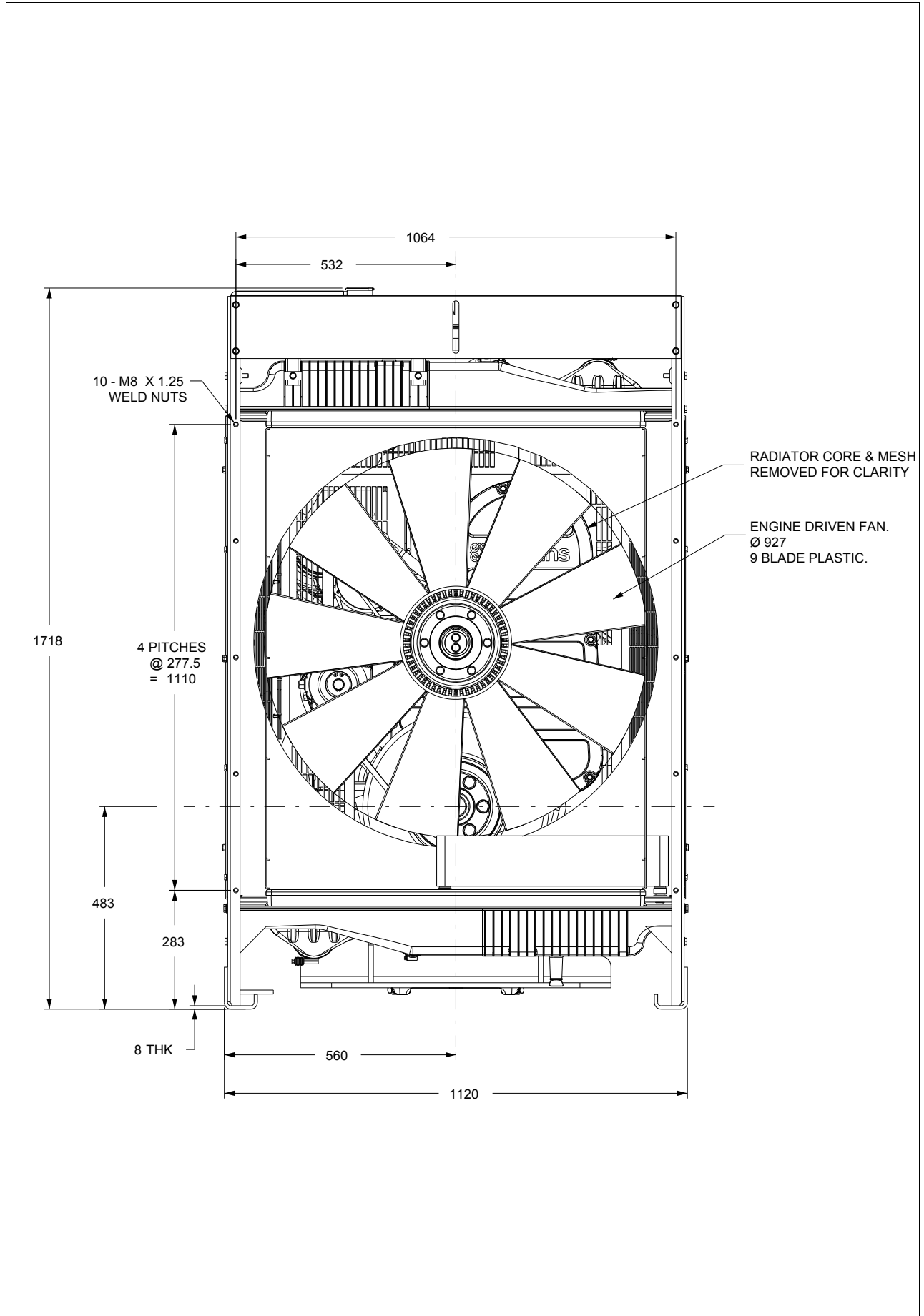

Note: This drawing is for reference only. For installation purposes, please refer to the relevant General Installation drawing (Z13579).

2506C-E15TAG3 and 2506C-E15TAG4 - right side view

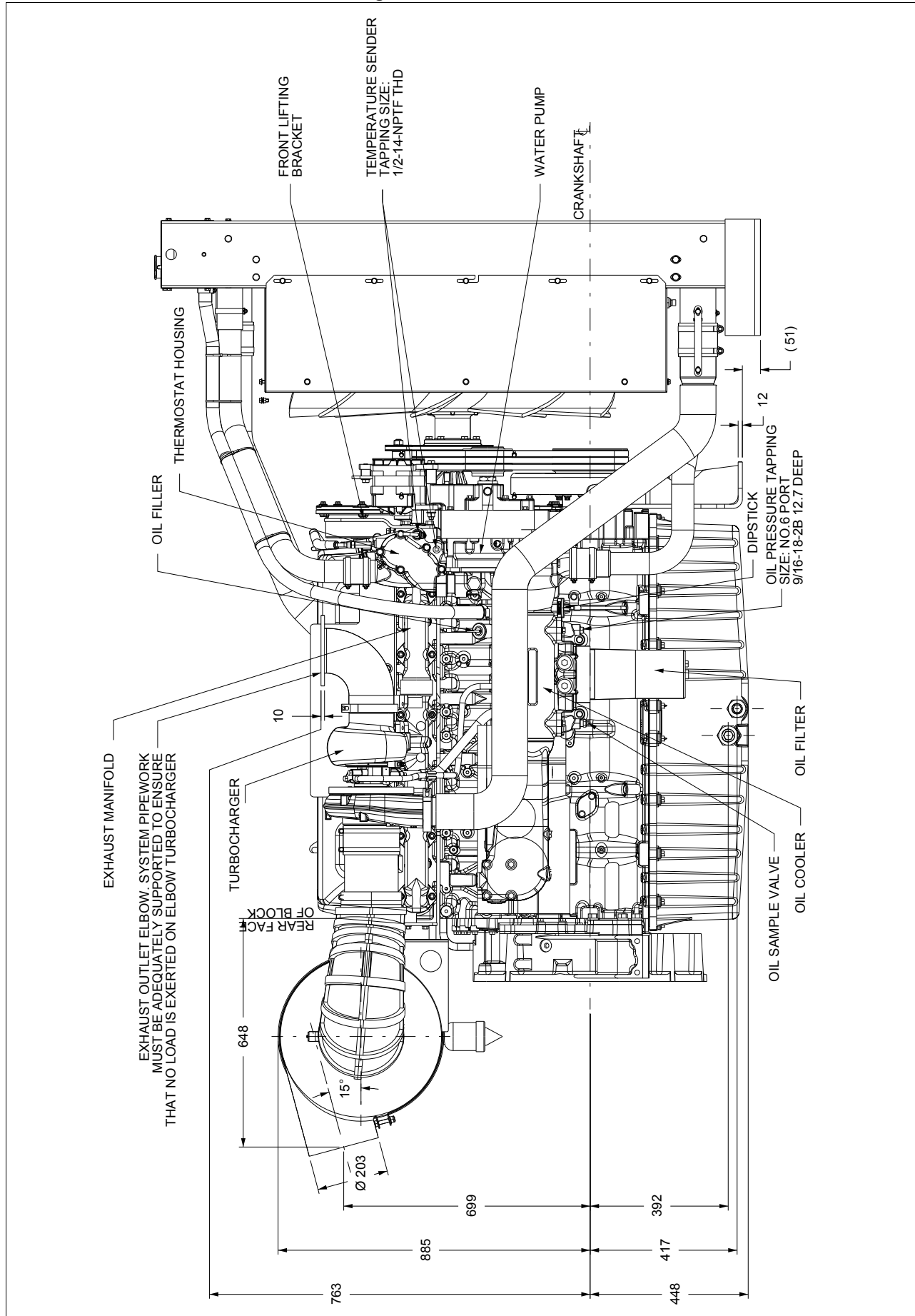

Note: This drawing is for reference only. For installation purposes, please refer to the relevant General Installation drawing (Z13579).

2506C-E15TAG3 and 2506C-E15TAG4 - rear view

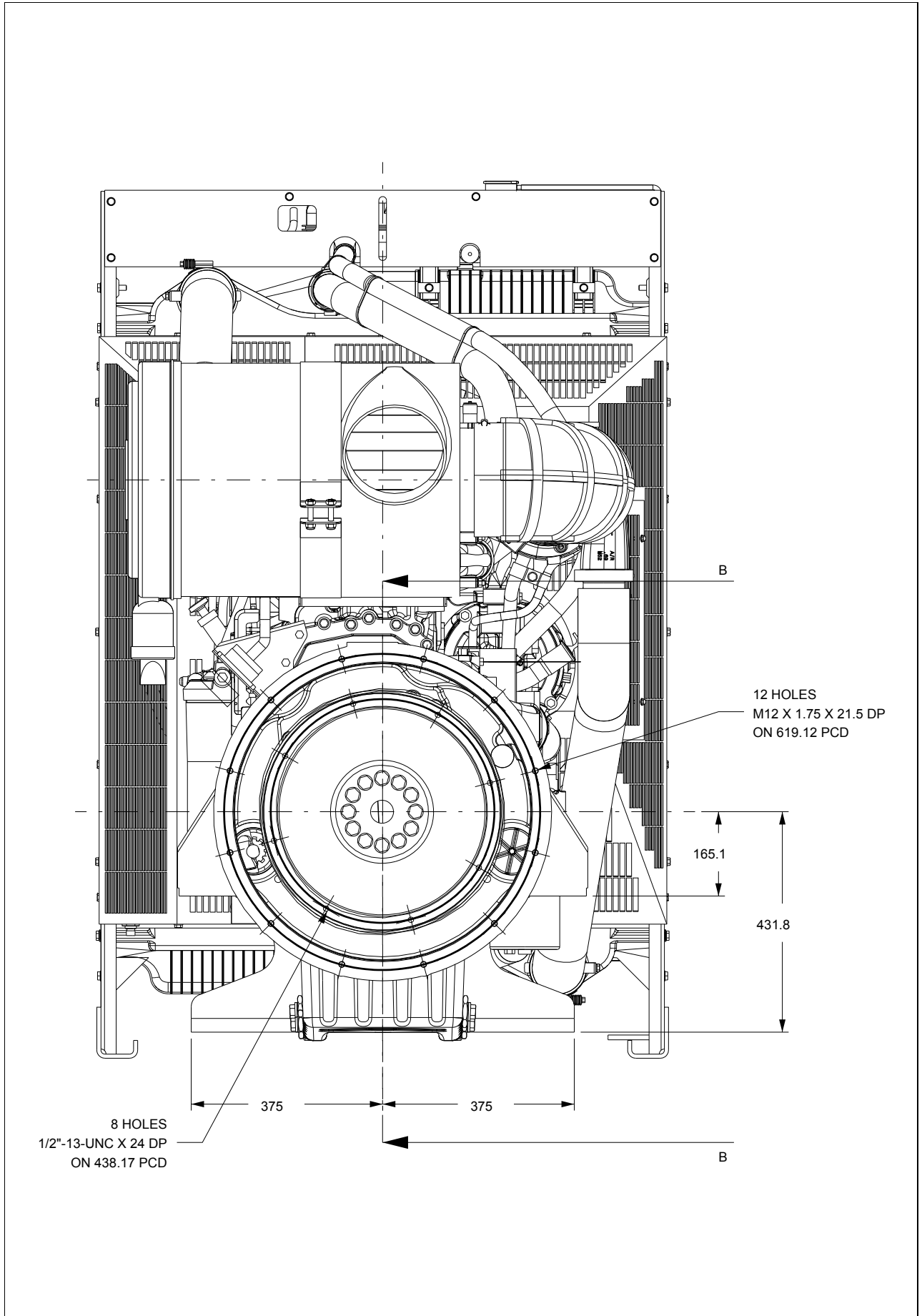

Note: This drawing is for reference only. For installation purposes, please refer to the relevant General Installation drawing (Z13579).

2506C-E15TAG3 and 2506C-E15TAG4 - plan view

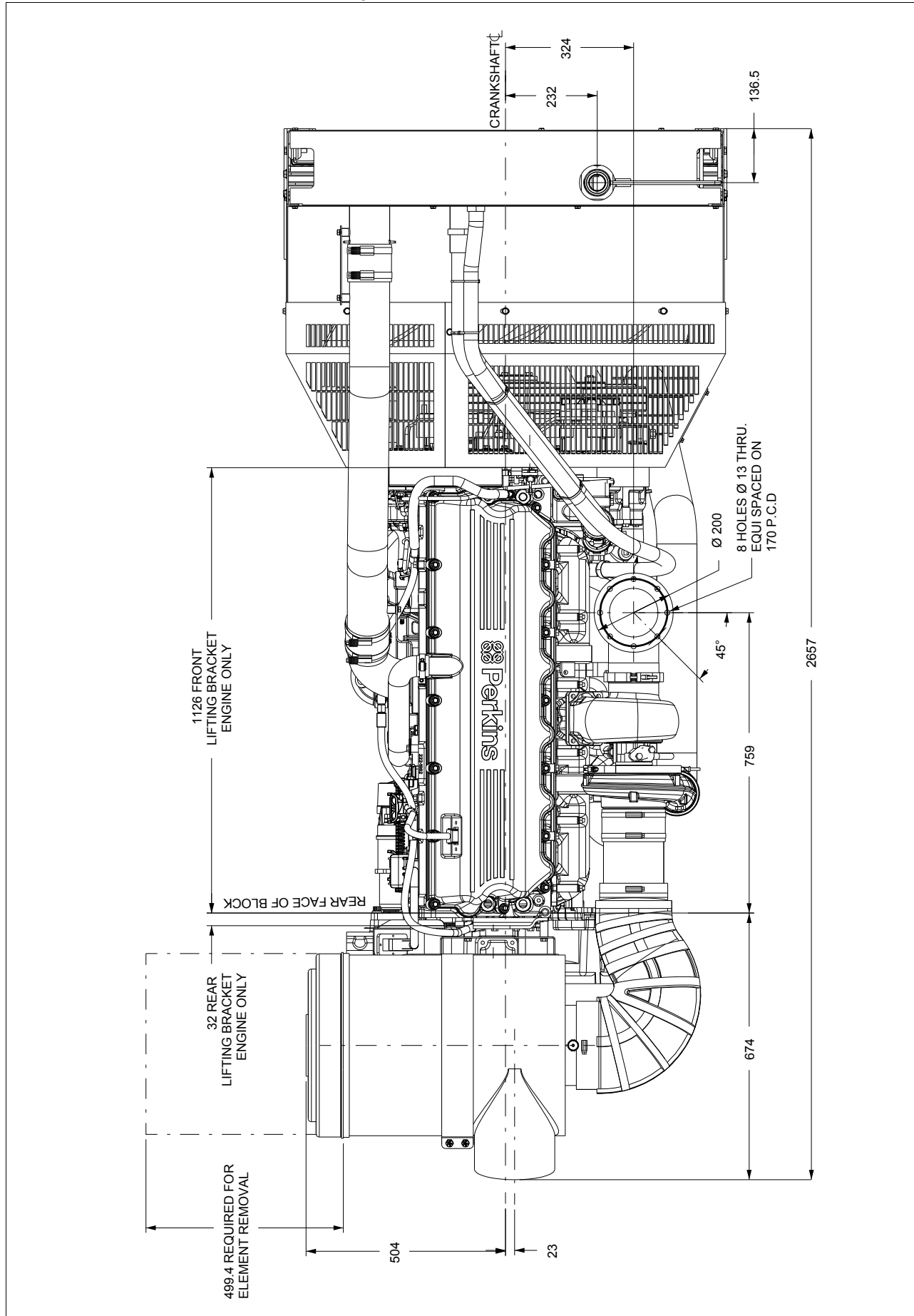

Note: This drawing is for reference only. For installation purposes, please refer to the relevant General Installation drawing (Z13579).

2506C-E15TAG3 and 2506C-E15TAG4 - miscellaneous views

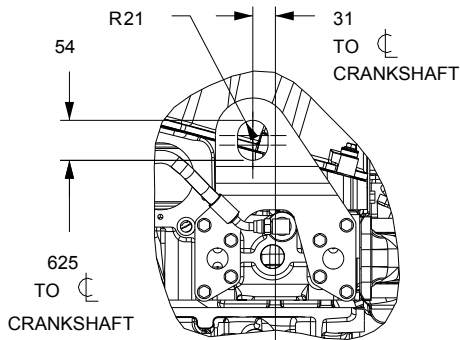

**SCRAP VIEW SHOWING
DETAILS OF REAR LIFTING
EYE**

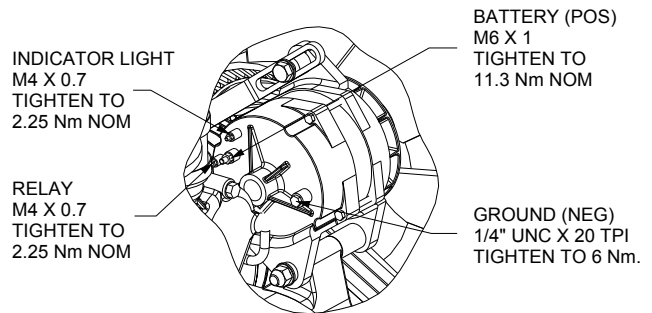

**SCRAP VIEW SHOWING ALTERNATOR CONNECTIONS.
FAN GUARDS & THERMOSTAT REMOVED FOR CLARITY.
SCALE 1:3**

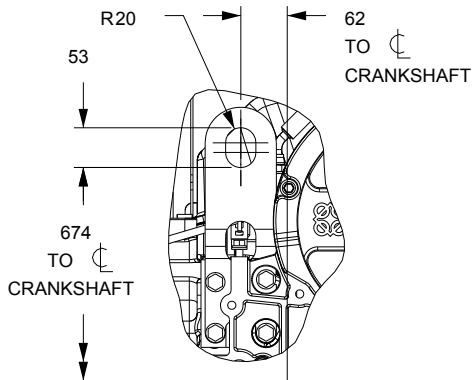

**SCRAP VIEW SHOWING
DETAILS OF FRONT LIFTING
EYE**

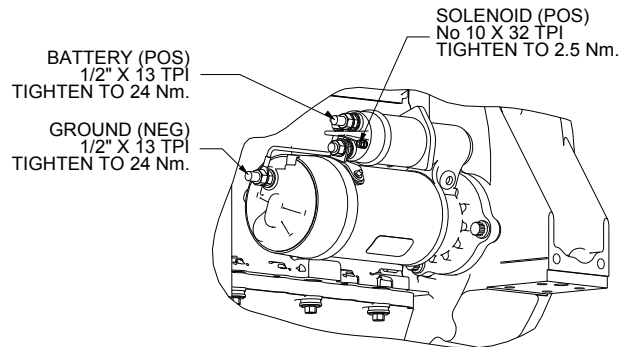

**SCRAP VIEW SHOWING
STARTER MOTOR CONNECTIONS
SCALE 1:3**

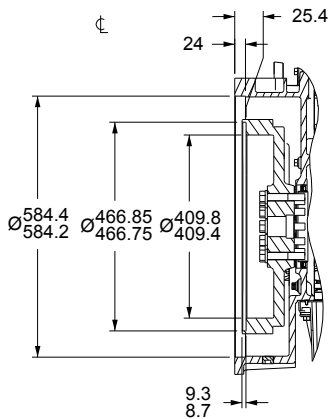

**SECTION B-B
DETAILS OF SAE 1 / 2 FLYWHEEL HOUSING
AND SAE J620 SIZE 14 FLYWHEEL**

Note: This drawing is for reference only. For installation purposes, please refer to the relevant General Installation drawing (Z13579).

Cooling system

Recommended coolant:

50% inhibited ethylene glycol or 50% inhibited propylene glycol and 50% clean fresh water. Where there is no likelihood of ambient temperatures below 10 °C, clean 'soft' water may be used, treated with 1% by volume of Perkins inhibitor in the cooling system. The inhibitor is available from all Perkins Distributors.

Total system coolant capacity 58,0 litres
 Maximum pressure:
 -in crankcase water jacket 276 kPa
 Maximum top tank temperature 107 °C
 Maximum static pressure on pump 170 kPa
 Maximum permissible restriction:
 -to coolant pump flow 30 kPa
 Temperature rise across engine with inhibited coolant:
 -standby power 10 °C
 -prime power 9 °C
 Thermostat operation range 88 to 98 °C

Radiator

-face area 1.238 m²
 -weight (dry) 132 kg
 -rows and materials 2 rows, Aluminium
 -matrix density and material 12 fins per inch, Aluminium
 -width of matrix 1048 mm
 -height of matrix 1100 mm
 -pressure cap setting (minimum) 69 kPa

Charge cooler with integral radiator

-face area 1.006 m²
 -number of rows and material 1 row, Aluminium
 -matrix density and material 12,5 fins per inch, Aluminium
 -width of matrix 915 mm
 -height of matrix 1100 mm

Coolant pump

Speed 1946 rev/min
 Method of drive gear

Fan

-diameter 927 mm
 -drive ratio 0.92:1
 -number of blades 9
 -material B3WG6 or PA6GF30 Nylon 6 glass filled 30%
 -type ACS 367500

Cooling clearance

Ambient cooling clearance (standby power) based on air temperature at fan of 6 °C above the ambient

2506C-E15TAG3 maximum additional restriction (duct allowance) to cooling airflow and resultant minimum airflow			
Duct allowance with inhibited coolant at 50 °C			
Description	rev/min	Units	Standby
Duct allowance	1800	kPa	0.125
Minimum airflow	1800	m ³ /min	822
Duct allowance with 50% glycol at 43 °C			
Duct allowance	1800	kPa	0.200
Minimum airflow	1800	m ³ /min	792

2506C-E15TAG4 maximum additional restriction (duct allowance) to cooling airflow and resultant minimum airflow			
Duct allowance with inhibited coolant at 50 °C			
Description	rev/min	Units	Standby
Duct allowance	1800	kPa	0.125
Minimum airflow	1800	m ³ /min	822
Duct allowance with 50% glycol at 43 °C			
Duct allowance	1800	kPa	0.200
Minimum airflow	1800	m ³ /min	792

Electrical system

Type 12V negative earth
 Alternator
 -type 22SI
 -voltage 24 volts
 -output 70 amps
 Starter
 -type 42MT
 -motor voltage 24 volts
 -motor power 7,5 kW
 Number of teeth
 -on the flywheel 113
 -on starter pinion 11
 Minimum cranking speed 100 rev/min
 Pull-in current of starter motor solenoid
 @ -25 °C max ⁽¹⁾ 57 amps
 Hold-in current of starter motor solenoid
 @ -25 °C max ⁽¹⁾ 16 amps

1. All leads to rated at 10 amps minimum

Cold start recommendations

Temperature Range	
5 to -10 °C (41 to 14 °F)	Oil 15W40
	Starter 42MT
	Battery 2x 12V 128 Ah
	Max breakaway current 1250 amps
	Cranking current 676 amps
	Aids None
	Minimum mean cranking speed 120 rev/min

Temperature Range	
-11 to -25 °C (12.2 to -13 °F)	Oil 0W40
	Starter 42MT
	Battery 2x 12V 128 Ah
	Max breakaway current 1250 amps
	Cranking current 880 amps
	Aids block heater 1.5 kW
	Minimum mean cranking speed 120 rev/min

- Battery capacity is defined by the 20 hour rate
- The oil specification should be for the minimum ambient temperature as the oil will not be warmed by the immersion heater
- Breakaway current is dependent on battery capacity available. Cables should be capable of handling the transient current which may be up to double the steady cranking current.

Exhaust system

Maximum back pressure 6,8 kPa
 Exhaust outlet size (internal) 127 mm

Recommended exhaust pipe diameter

length	mm
up to 10m	150
10m to 20m	150
20m to 30m	200

Fuel system

Type of injection MEUI
 Injector type..... MEUI
 Injector pressure 200 MPa

Fuel lift pump

type gear driven
 Delivery flow 457 litres/hr
 Pressure 550 kPa
 Maximum suction head at pump inlet 3 m
 Maximum static pressure head 4 m
 Fuel inlet temperature to be less than 55 °C
 Governor type electronic
 Governing to ISO 8528-5 class G3 steady state

Fuel filtration level

-primary 10 µm
 -secondary 2 µm

Fuel consumption

2506C-E15TAG3

Designation	Fuel consumption calculated on nett rated powers	
	g/kWh	litres/hr
Standby	210,0	132,0
Prime + 10%	210,0	132,0
Prime	211,0	121,0
At 75% of Prime	223,0	96,0
At 50% of Prime	268,5	77,0

2506C-E15TAG4

Designation	Fuel consumption calculated on nett rated powers	
	g/kWh	litres/hr
Standby	211	146

Induction system

Maximum air intake restriction

-clean filter 3,7 kPa
 -dirty filter 6,2 kPa
 -air filter type paper element 457 mm diameter

Lubrication system

The recommended SAE viscosity is a multigrade oil (15W40) which adequately meets the specifications of API CI4

Total system capacity ... 60,0 litres
Maximum sump capacity ... 53,0 litres
Minimum sump capacity ... 45,0 litres

Lubricating oil pressure

-at rated speed ... 420 kPa
Nominal (minimum) ... 200 kPa
Oil relief valve opens:
-with pressure difference of ... 255 +/- 20 kPa
Oil filter screen spacing... 30 µm
Sump drain plug tapping size. ... M24
Oil pump speed and drive method ... 1,16 x engine speed, gear
Oil flow at full load rated speed... 3,4 litres/sec
Oil consumption at full load rated speed ... 0,1%
Oil temperature (in rail)
-maximum continuous operation ... 114 °C

Normal operating angles

-front and rear ... 7°
-side tilt... 7°

Recommended SAE viscosity

A single or multigrade oil must be used which conforms API CI4 or ACEA E5. miscellaneous views

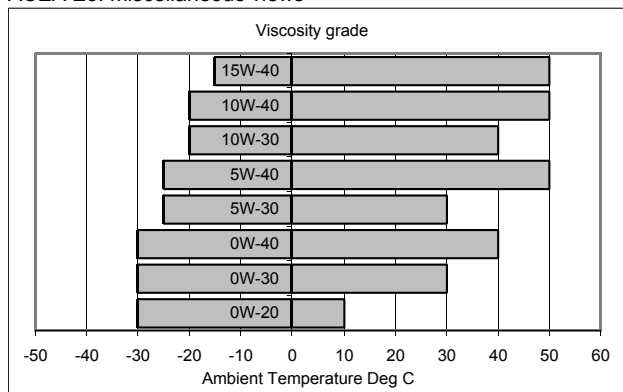

Mountings

Maximum static bending moment at rear face of block ... 1356 Nm

Centre of gravity (bare dry engine)

-forward of rear face of cylinder block ... 570 mm
-above crankshaft centre line ... 240 mm

Engine management system

Full electronic engine management system controlling:

- speed governing
- air / fuel ratio
- start / stop sequence
- engine protection and diagnostics

Typical load acceptance

2506C-E15TAG3

Engine speed	Initial Load Acceptance When engine reaches rated speed (15 seconds maximum after engine starts to crank)				2nd Load Application Immediately after engine has recovered to rated speed (5 seconds after initial load application)			
	Prime Power %	Load kWm (kWe) Nett	Transient Frequency Deviation %	Frequency recovery time seconds	Prime Power %	Load kWm (kWe) Nett	Transient Frequency Deviation %	Frequency recovery time seconds
1800 rev/min	60	273	≤ 10	5	55	250	≤ 10	5

2506C-E15TAG4

Engine speed	Initial Load Acceptance When engine reaches rated speed (15 seconds maximum after engine starts to crank)				2nd Load Application Immediately after engine has recovered to rated speed (5 seconds after initial load application)			
	Prime Power %	Load kWm (kWe) Nett	Transient Frequency Deviation %	Frequency recovery time seconds	Prime Power %	Load kWm (kWe) Nett	Transient Frequency Deviation %	Frequency recovery time seconds
1800 rev/min	55	275	≤ 10	5	50	250	≤ 10	5

The above figures were obtained under test conditions as follows:

Engine block temperature 45 °C
 Ambient temperature 15 °C
 Governing mode Isochronous
 Alternator inertia 8 kgm²
 Under frequency roll off (UFRO) point set to 1 Hz below rated frequency
 UFRO rate set to 2 % voltage / 1% frequency
 LAM on / off off

All tests were conducted using an engine installed and serviced to Perkins Engines Company Limited recommendations.

The applied load is a percentage of generator electrical output, using alternator efficiencies as published in the general installation section of this Technical Data Sheet.

The information given on this Technical Data Sheet is for standard ratings only. For ratings other than those shown, please contact Perkins Engines Company Limited, Stafford.

The information given in this document is for guidance only.

Notes



Perkins Engines Company Limited
Peterborough PE1 5NA United Kingdom
Telephone +44 (0) 1733 583000
Fax +44 (0) 1733 582240
www.perkins.com

All information in the document is substantially correct at the time of printing but may be subsequently altered by the company.

Distributed by