

*ENGINE DATASHEET*



# 2500 Series 2506D-E15TAG1 Diesel Engine – ElectropaK

490 kWm at 1800 rpm

The 2500 Series engine has been developed using the latest engineering techniques and builds on the strengths of the already very successful 2000 Series family and addresses today's uncompromising demands within the power generation industry. Developed from a proven heavy-duty industrial base these products offer superior performance and reliability.

The 2506D-E15TAG1 is a turbocharged and air-to-air charge-cooled, 6 cylinder diesel engine. Its premium features provide economic and durable standby duty, exceptional power-to-weight ratio resulting in exceptional fuel consumption and low gaseous emissions and advanced overall performance and reliability making this the prime choice for today's power generation industry.

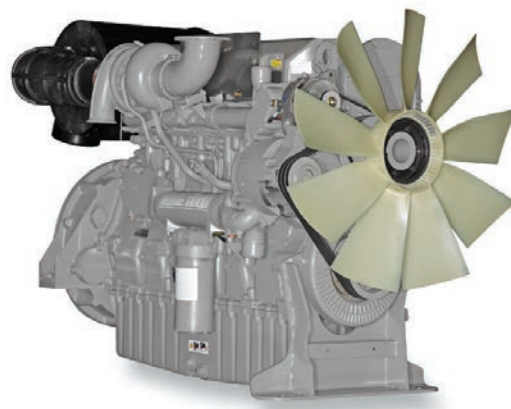

## Economic power

- Mechanically operated unit fuel injectors with advanced electronic control, combined with carefully matched turbocharging, give excellent fuel atomisation which leads to exceptional low fuel consumption

## Reliable power

- Developed and tested using the latest engineering techniques and finite element analysis for high reliability
- Low oil usage and low wear rates
- High compression ratio ensures clean rapid starting in all conditions
- Perkins global product support is designed to enhance the customer experience of owning a Perkins powered machine. We deliver this through the quality of our distribution network, extensive global coverage and a range of Perkins supported OEM partnership options. So whether you are an end-user or an equipment manufacturer our engine expertise is essential to your success

## Compact, clean and efficient power

- Exceptional power to weight ratio and compact size gives optimum power density for ease of installation and more cost effective transportation

- Designed to provide excellent service access for ease of maintenance

## Product support

- Perkins actively pursues product support excellence by ensuring our distribution network invest in their territory – strengthening relationships and providing more value to you, our customer
- Through an experienced global network of distributors and dealers, fully trained engine experts deliver total service support around the clock, 365 days a year. They have a comprehensive suite of web based tools at their fingertips covering technical information, parts identification and ordering systems, all dedicated to maximising the productivity of your engine
- Throughout the entire life of a Perkins engine, we provide access to genuine OE specification parts and service. We give 100% reassurance that you receive the very best in terms of quality for lowest possible cost .. wherever your Perkins powered machine is operating in the world

*Certified against the requirements of Tier 3 legislation for non-road mobile machinery, powered by constant speed engines (EPA 40 CFR Part 89 Tier 3)*

Engine Speed rpm	Type of Operation	Typical Generator Output (Net)		Engine Power			
				Gross		Net	
		kVA	kWe	kWm	bhp	kWm	bhp
1800	Prime Power	500	400	458	615	435	583
	Standby Power	563	450	514	689	490	657

The above ratings represent the engine performance capabilities to conditions specified in ISO 8528/1, ISO 3046/1:1986, BS 5514/1. Derating may be required for conditions outside these; consult Perkins Engines Company Limited.

Generator powers are typical and are based on an average alternator efficiency and a power factor (cos.  $\theta$ ) of 0.8. Fuel specification: BS 2869: Part 2 1998 Class A2 or ASTM D975 D2. Lubricating oil: 15W40 to API CI4.

### Rating Definitions

**Prime Power:** Power available at variable load with a load factor not exceeding 80% of the prime power rating. Overload of 10% is permitted for 1 hour in every 12 hours' operation.

**Standby Power:** Power available in the event of a main power network failure up to a maximum of 500 hours per year of which up to 300 hours may be run continuously. Load factor may be up to 100% of standby power. No overload is permitted.

Photographs are for illustrative purposes only and may not reflect final specification.

All information in this document is substantially correct at time of printing and may be altered subsequently. Publication No. PN1849/07/14 Produced in England ©2014 Perkins Engines Company Limited



THE HEART OF EVERY GREAT MACHINE

# 2500 Series 2506D-E15TAG1 Diesel Engine – ElectropaK

490 kWm at 1800 rpm

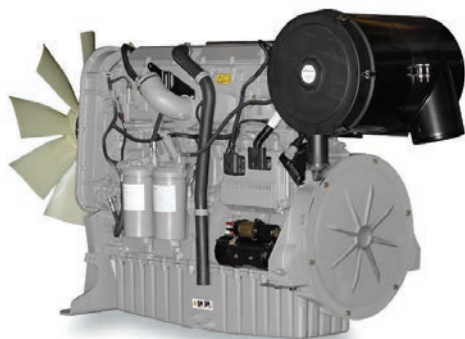

## Standard ElectropaK specification

### Air inlet

- Mounted air filter

### Fuel system

- Mechanically actuated electronically controlled unit fuel injectors with full authority electronic control
- Governing to ISO 8528-5 class G3 with isochronous capability
- Replaceable 'Ecoplus' fuel filter elements with primary filter/water separator
- Fuel cooler

### Lubrication system

- Wet sump with filler and dipstick
- Full-flow replaceable 'Ecoplus' filter
- Oil cooler integral with filter header

### Cooling system

- Gear-driven circulating pump
- Mounted belt-driven fan
- Radiator supplied loose incorporating air-to-air charge cooler
- System designed for ambients up to 50°C

### Electrical equipment

- 24 volt starter motor and 24 volt 70 amp alternator with DC output
- ECM mounted on engine with wiring looms and sensors
- 3 level engine protection system

### Flywheel and housing

- High inertia flywheel to SAE J620 size 14
- SAE ½ flywheel housing

### Mountings

- Front engine mounting bracket

## Optional equipment

- 110 volt/240 volt immersion heater
- Additional speed sensor
- Temperature and pressure sensors for gauges
- Air filter rain hood
- Twin starters/facility for second starter
- Tool kit
- Additional manuals
- Closed circuit crankcase ventilation system

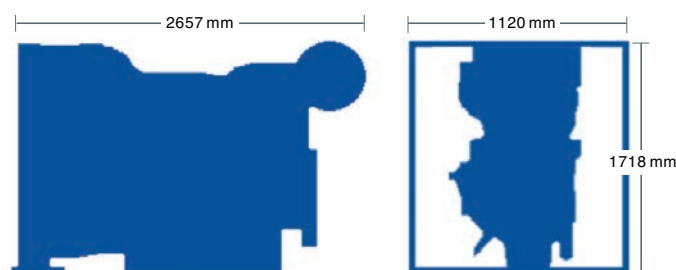

Fuel Consumption		
Engine Speed	1800 rpm	
	g/kWh	l/hr
Standby	222	126
Prime Power	225	113
75% of Prime Power	245	93
50% of Prime Power	267	67

## General data

Number of cylinders .....	6
Cylinder arrangement .....	Vertical in-line
Cycle .....	4 stroke
Induction system .....	Turbocharged and air-to-air charge cooled
Combustion system .....	Direct injection
Cooling system .....	Water-cooled
Bore and stroke .....	137 x 171 mm (5.4 x 6.7 in)
Displacement .....	15.2 litres (927.5 cubic in)
Compression ratio .....	16:1
Direction of rotation .....	Anti-clockwise, viewed on flywheel
Total lubrication system capacity .....	62 litres (16.4 US gal)
Total coolant capacity .....	58 litres (15.3 gal)
Dimensions – Length .....	2657 mm (104.6 in)
Width .....	1120 mm (44 in)
Height .....	1718 mm (67.6 in)
Dry weight (ElectropaK) .....	1,633 kg (3600 lb)
Final weight and dimensions will depend on completed specification	

Photographs are for illustrative purposes only and may not reflect final specification.

All information in this document is substantially correct at time of printing and may be altered subsequently.  
Publication No. PN1849/07/14 Produced in England  
©2014 Perkins Engines Company Limited

## Perkins Engines Company Limited

Peterborough PE1 5FQ  
United Kingdom  
Telephone +44 (0)1733 583000  
Fax +44 (0)1733 582240  
[www.perkins.com](http://www.perkins.com)



THE HEART OF EVERY GREAT MACHINE

# Technical Data

## 2500 Series

# 2506D-E15TAG1

### Diesel Engine - ElectropaK

#### Basic technical data

Number of cylinders	6
Cylinder arrangement	Vertical, In-line
Cycle	4 stroke
Induction system	turbocharged, air to air charge cooling
Combustion system	direct injection
Compression ratio	16:1
Bore	137 mm
Stroke	171 mm
Cubic capacity	15,2 litres
Direction of rotation	anti-clockwise viewed on flywheel
Firing order (cylinder 1 furthest from flywheel)	1, 5, 3, 6, 2, 4

#### Total weight of ElectropaK

-dry (engine only)	1633 kg
-wet	1714 kg

#### Overall dimensions of ElectropaK

-height	1718 mm
-length	2657 mm
-width	1120 mm

#### Moments of inertia (mk<sup>2</sup>)

Engine	2,3291 kgm <sup>2</sup>
Flywheel	1,96355 kgm <sup>2</sup>

#### Performance

**Note:** All data based on operation to ISO 3046/1, BS5514 and DIN 6271 standard reference conditions.

#### Cyclic irregularity

Engine / Flywheel maximum:	1:60
----------------------------	------

#### Ratings

Steady state stability at constant speed  $\pm 0.25\%$   
 Electrical ratings are based on average alternator efficiency and are for guidance only (0.8 power factor being used)

#### Operating point

Engine speed	1800 rev/min
Cooling water maximum exit temperature	< 107 °C

#### Fuel data

To conform to BS2869 class A2 or BS EN590

#### Test conditions

-air temperature	25 °C
-barometric pressure	100 kPa
-relative humidity	30%
-air inlet restriction at maximum power (nominal)	2,5 kPa
-exhaust back pressure at maximum power (nominal)	6,0 kPa
-maximum fuel temperature (inlet pump)	40 °C

**Note:** If the engine is to operate in ambient conditions other than those of the test conditions, suitable adjustments must be made for these changes. For full details, contact Perkins Technical Service Department. For test conditions relevant to data on load acceptance, refer to the bottom of page 12.

#### Sound level

Estimated sound pressure at 1 metre	105,2 dB(A)
-------------------------------------	-------------

## General installation

Designation	Units	Type of operation and application	
		Prime	Standby
		60 Hz @ 1800 rev/min	
Gross engine power	kWb	458	514
Fan power	kWm	15.5	
Restriction losses	kWm	8	8,9
ElectropaK nett engine power	kWm	435	490
Gross brake mean effective pressure	kPa	2036	2284
Combustion air flow	m³/min	39.3	41,5
Exhaust gas temperature (max)	°C	N/A	550
Exhaust gas flow	m³/min	104,5	112
Boost pressure ratio	-	3,26	3,43
Overall thermal efficiency (nett)	%	37,4	38,1
Friction and pumping power losses	kWm	51	
Mean piston speed	m/s	10	
Engine coolant flow	l/sec	7,2	
Cooling fan air flow (zero duct allowance)	m³/min	866	
Typical Gen Set electrical output (0.8 pf)	kWe	400	450
	kVA	500	563
Assumed alternator efficiency	%	92	

## Rating definitions

### Prime power

Variable load. Unlimited hours usage with an average load factor of 80% of the published Prime Power rating over each 24 hour period. A 10% overload is available for 1 hour in every 12 hours operation

### Standby power

Variable load. Limited to 500 hours annual usage up to 300 hours of which may be continuous running. No overload is permitted

### Emissions capability

Certified against the requirements of Tier 3 legislation for non-road mobile machinery, powered by constant speed engines (EPA 40 CFR Part 89 Tier 3).

## Energy balance

Designation	Units	Type of operation and application	
		Prime	Standby
		60 Hz @ 1800 rev/min	
Energy in fuel	kWt	1200	1320
Energy in power output (gross)	kWb	458	514
Energy to cooling fan and restrictions	kWm	23,5	24,4
Energy in power output (nett)	kWm	435	490
Energy to exhaust	kWt	420	465
Energy to coolant and oil	kWt	170	178
Energy to radiation	kWt	38	35
Energy to charge cooler	kWt	114	128

2506D-E15TAG1 - left side view

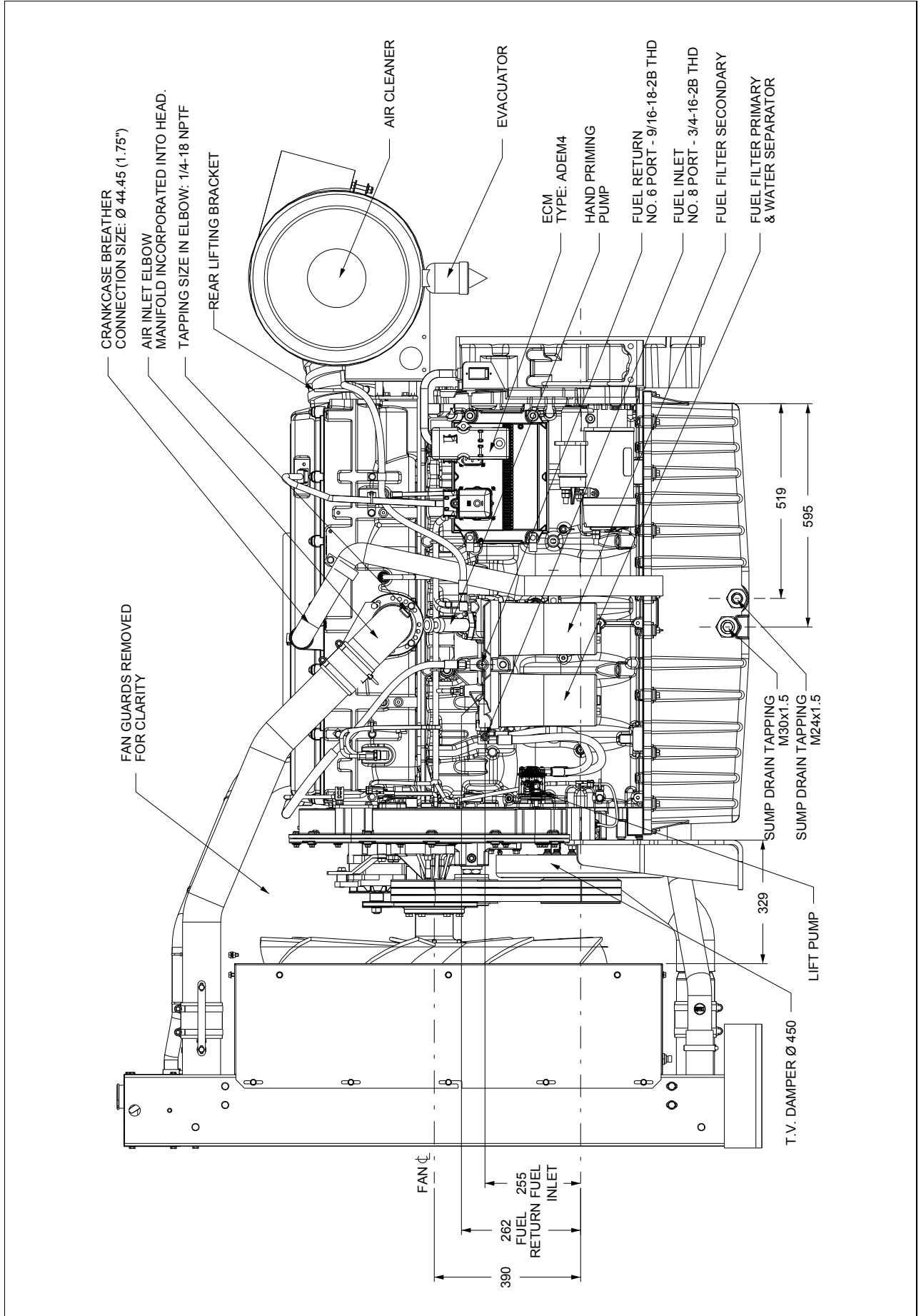

**Note:** This drawing is for reference only. For installation purposes, please refer to the relevant General Installation drawing (Z13579).

2506D-E15TAG1 - front view

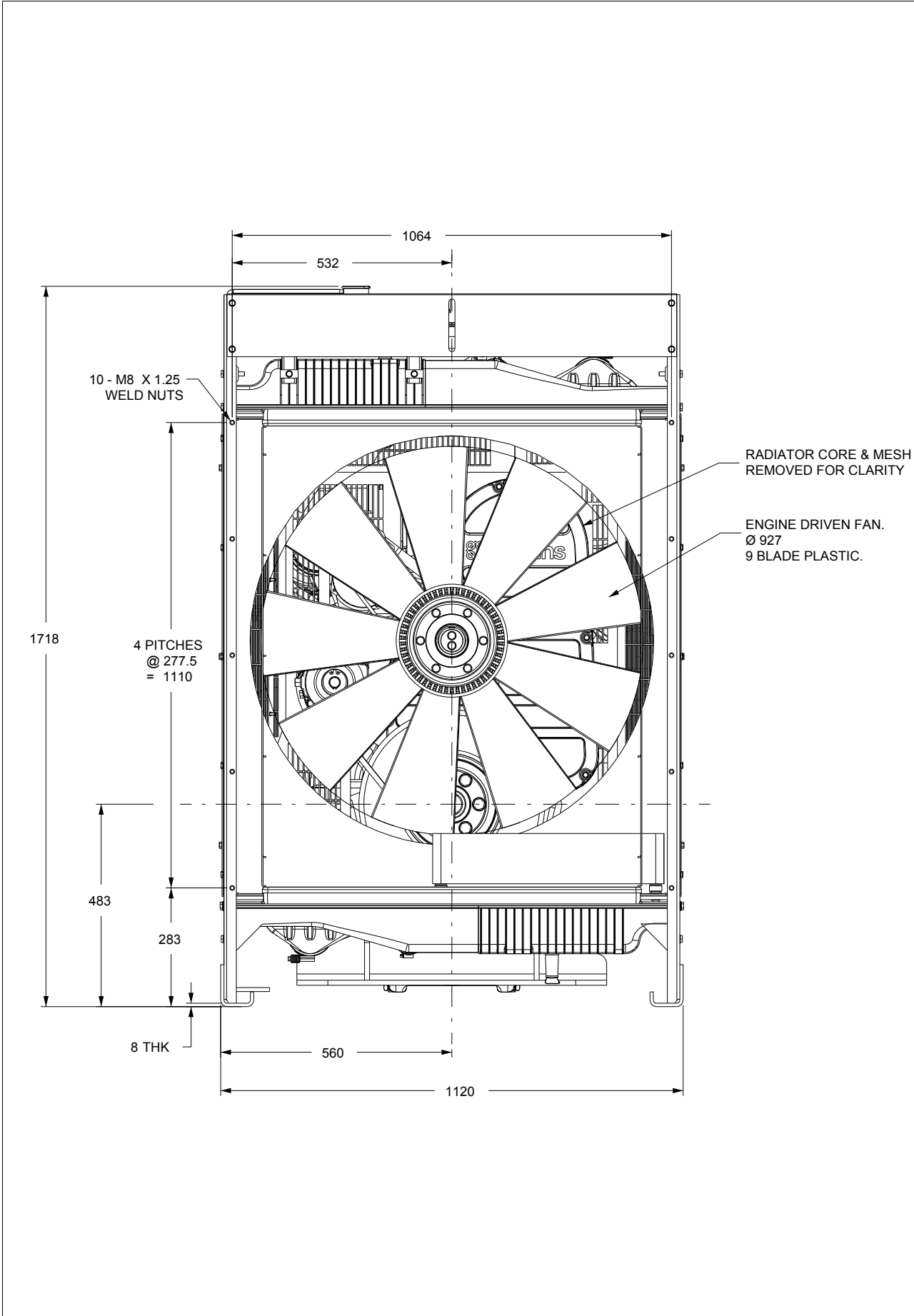

Note: This drawing is for reference only. For installation purposes, please refer to the relevant General Installation drawing (Z13579).

2506D-E15TAG1 - right side view

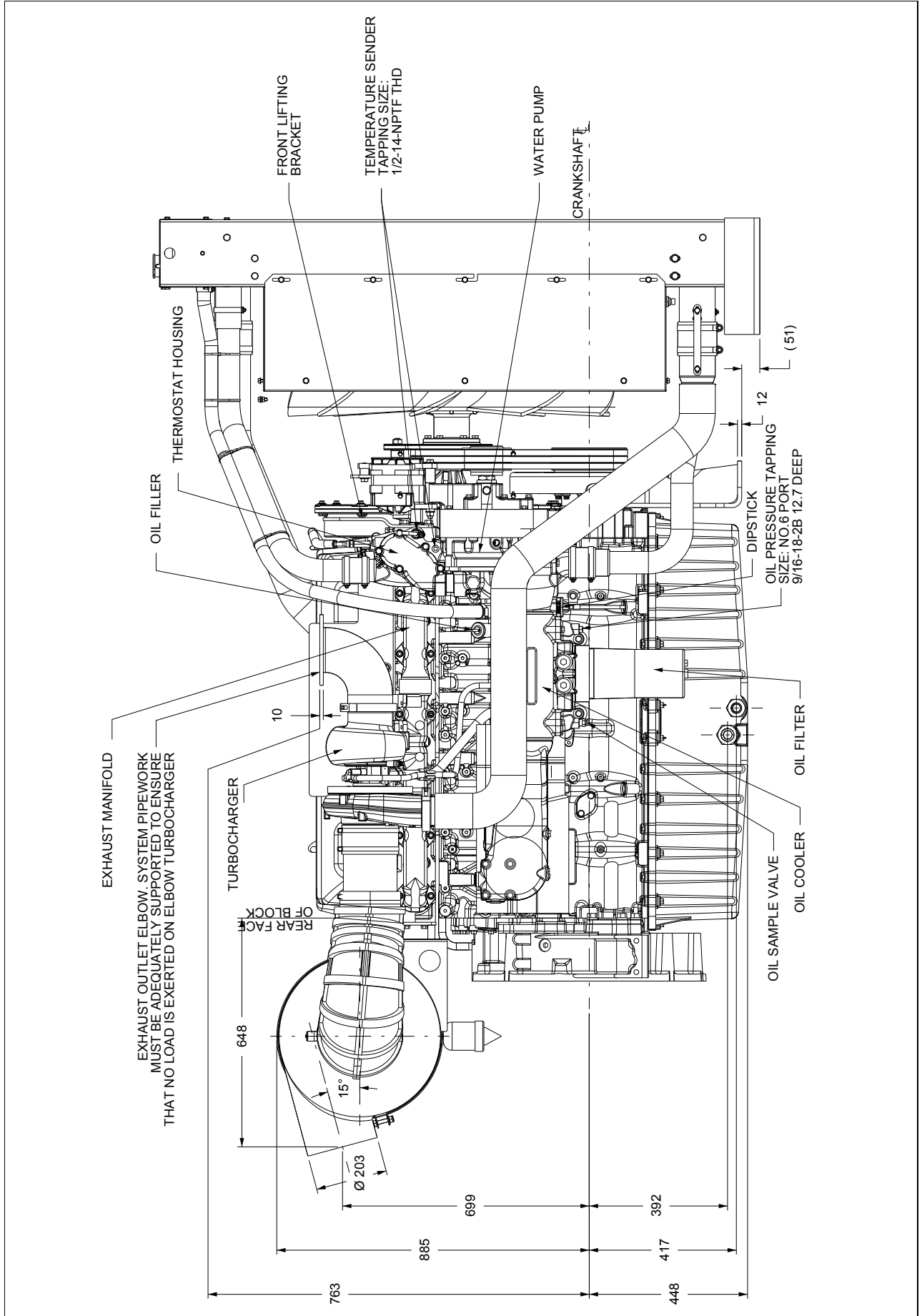

Note: This drawing is for reference only. For installation purposes, please refer to the relevant General Installation drawing (Z13579).



2506D-E15TAG1 - rear view

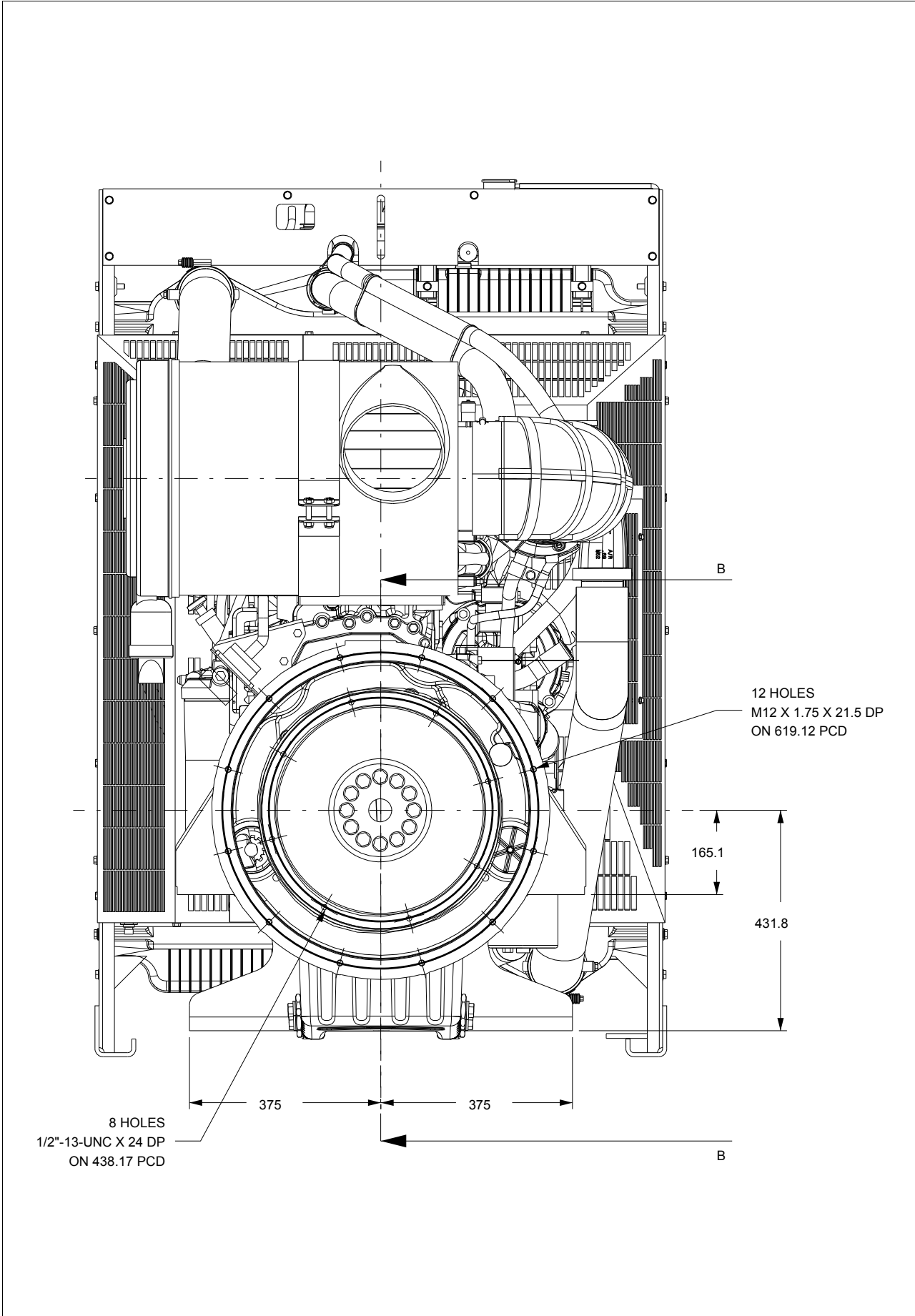

**Note:** This drawing is for reference only. For installation purposes, please refer to the relevant General Installation drawing (Z13579).

2506D-E15TAG1 - plan view

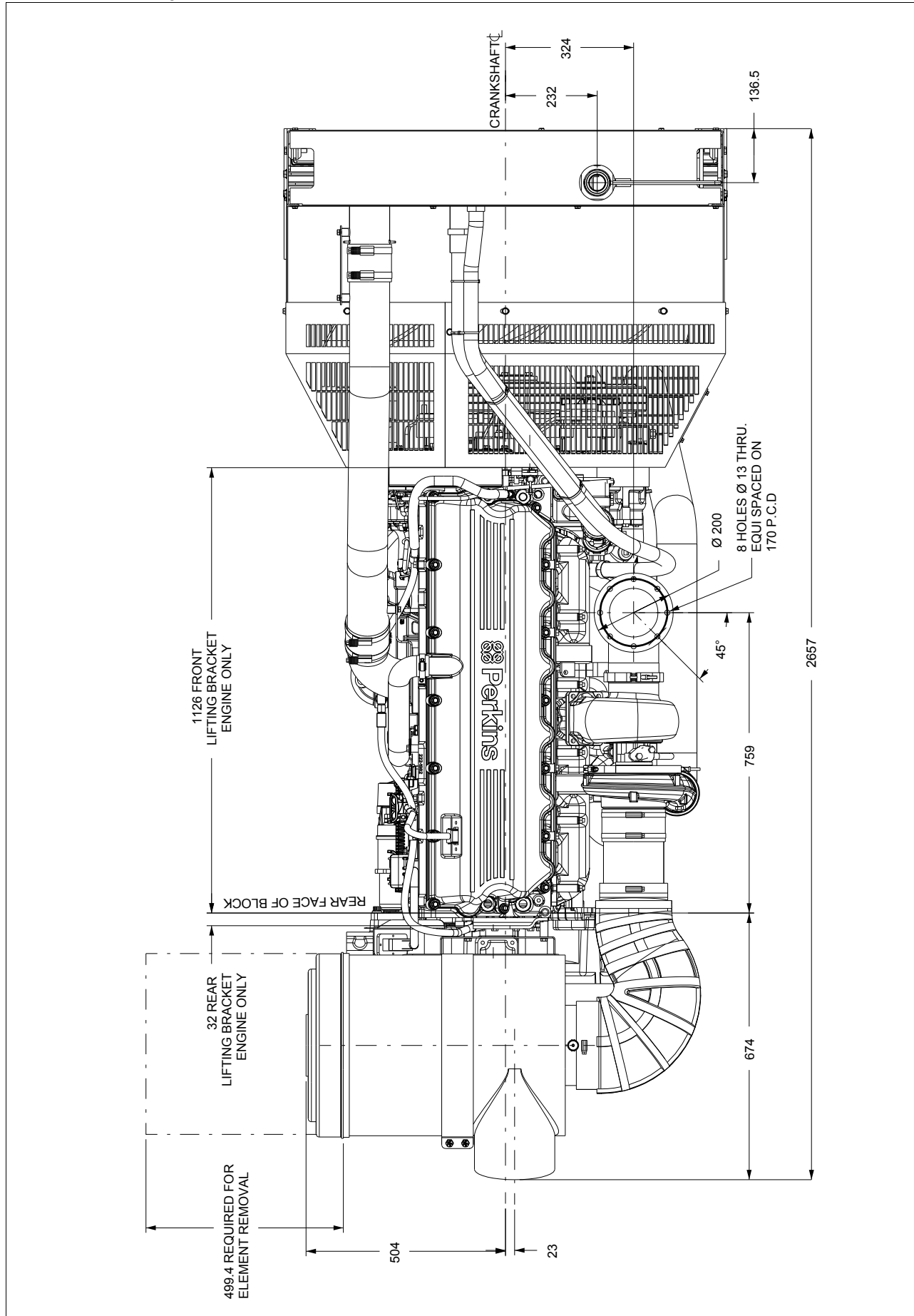

**Note:** This drawing is for reference only. For installation purposes, please refer to the relevant General Installation drawing (Z13579).

**2506D-E15TAG1 - miscellaneous views**

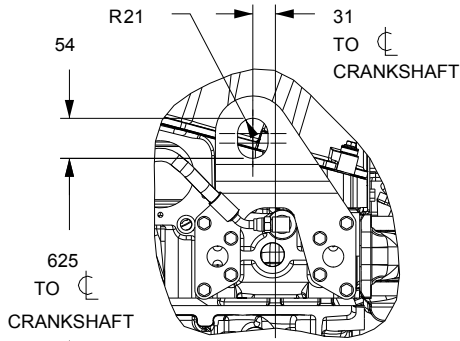

**SCRAP VIEW SHOWING  
DETAILS OF REAR LIFTING  
EYE**

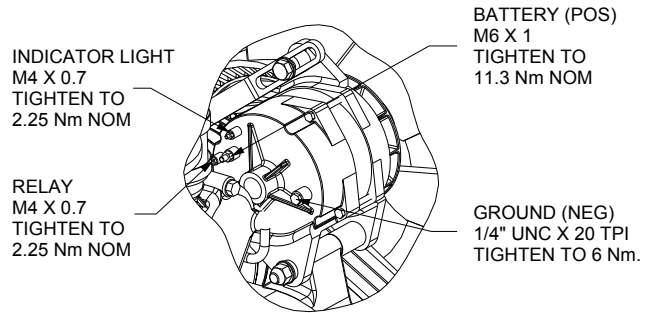

**SCRAP VIEW SHOWING ALTERNATOR CONNECTIONS.  
FAN GUARDS & THERMOSTAT REMOVED FOR CLARITY.  
SCALE 1:3**

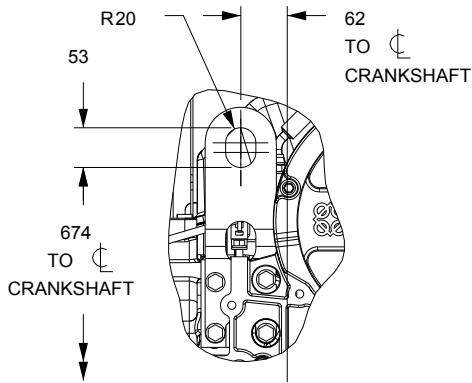

**SCRAP VIEW SHOWING  
DETAILS OF FRONT LIFTING  
EYE**

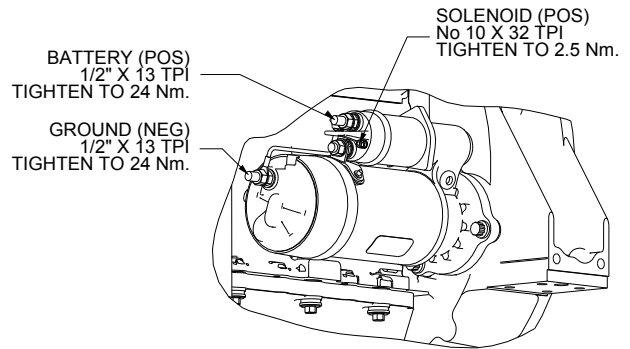

**SCRAP VIEW SHOWING  
STARTER MOTOR CONNECTIONS  
SCALE 1:3**

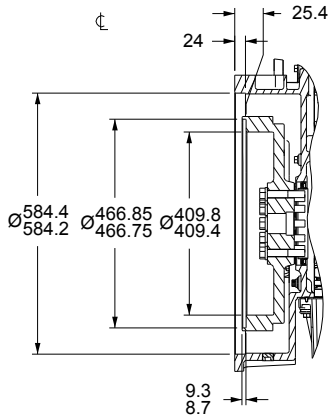

**SECTION B-B  
DETAILS OF SAE 1 / 2 FLYWHEEL HOUSING  
AND SAE J620 SIZE 14 FLYWHEEL**

**Note:** This drawing is for reference only. For installation purposes, please refer to the relevant General Installation drawing (Z13579).

## Cooling system

Recommended coolant:

50% inhibited ethylene glycol or 50% inhibited propylene glycol and 50% clean fresh water. Where there is no likelihood of ambient temperatures below 10 °C, clean 'soft' water may be used, treated with 1% by volume of Perkins inhibitor in the cooling system. The inhibitor is available from all Perkins Distributors.

Total system coolant capacity ... 58,0 litres  
 Maximum pressure:  
 -in crankcase water jacket ... 276 kPa  
 Maximum top tank temperature ... 107 °C  
 Maximum static pressure on pump ... 170 kPa  
 Maximum permissible restriction:  
 -to coolant pump flow ... 30 kPa  
 Temperature rise across engine with inhibited coolant  
 -standby power ... 10 °C  
 -prime power ... 9 °C  
 Thermostat operation range ... 88 to 98 °C

### Radiator

-face area ... 1.238 m<sup>2</sup>  
 -weight (dry) ... 132 kg  
 -rows and materials ... 2 rows, Aluminium  
 -matrix density and material ... 12 fins per inch, Aluminium  
 -width of matrix ... 1048 mm  
 -height of matrix ... 1100 mm  
 -pressure cap setting (minimum) ... 69 kPa

### Charge cooler with integral radiator

-face area ... 1.006 m<sup>2</sup>  
 -number of rows and material ... 1 row, Aluminium  
 -matrix density and material ... 12,5 fins per inch, Aluminium  
 -width of matrix ... 915 mm  
 -height of matrix ... 1100 mm

### Coolant pump

Speed: ... 1946 rev/min  
 Method of drive ... gear

### Fan

-diameter ... 927 mm  
 -drive ratio ... 0.92:1  
 -number of blades ... 9  
 -material ... B3WG6 or PA6GF30 Nylon 6 glass filled 30%  
 -type ... ACS 367500

## Cooling clearance

Ambient cooling clearance (standby power) based on air temperature at fan of 6 °C above the ambient

2506D-E15TAG1 maximum additional restriction (duct allowance) to cooling airflow and resultant minimum airflow			
Duct allowance with inhibited coolant at 50 °C			
Description	rev/min	Units	Standby
Duct allowance	1800	kPa	0.125
Minimum airflow	1800	m <sup>3</sup> /min	822
Duct allowance with 50% glycol at 43 °C			
Duct allowance	1800	kPa	0.200
Minimum airflow	1800	m <sup>3</sup> /min	792

## Electrical system

Type ... 12V negative earth  
 Alternator  
 -type ... 22SI  
 -voltage ... 24 volts  
 -output ... 70 amps  
 Starter  
 -type ... 42MT  
 -motor voltage ... 24 volts  
 -motor power ... 7,5 kW  
 Number of teeth  
 -on the flywheel ... 113  
 -on starter pinion ... 11  
 Minimum cranking speed ... 100 rev/min  
 Pull-in current of starter motor solenoid  
 @ -25 °C max <sup>(1)</sup> ... 57 amps  
 Hold-in current of starter motor solenoid  
 @ -25 °C max <sup>(1)</sup> ... 16 amps

1. All leads to rated at 10 amps minimum

## Cold start recommendations

Temperature Range	
5 to -10 °C (41 to 14 °F)	Oil: 15W40 Starter: 42MT Battery: 2x 12V 128 Ah Max breakaway current: 1250 amps Cranking current: 676 amps Aids: None Minimum mean cranking speed: 120 rev/min

Temperature Range	
-11 to -25 °C (12.2 to -13 °F)	Oil: 0W40 Starter: 42MT Battery: 2x 12V 128 Ah Max breakaway current: 1250 amps Cranking current: 880 amps Aids: block heater 1.5 kW Minimum mean cranking speed: 120 rev/min

- Battery capacity is defined by the 20 hour rate
- The oil specification should be for the minimum ambient temperature as the oil will not be warmed by the immersion heater
- Breakaway current is dependent on battery capacity available. Cables should be capable of handling the transient current which may be up to double the steady cranking current.

## Exhaust system

Maximum back pressure ..... 6,8 kPa

Exhaust outlet size (internal) ..... 127 mm

### Recommended exhaust pipe diameter

length	mm
up to 10m	150
10m to 20m	150
20m to 30m	200

## Fuel system

Type of injection ..... MEUI

Injector type ..... MEUI

Injector pressure ..... 200 MPa

### Fuel lift pump

type ..... gear driven

Delivery flow ..... 457 litres/hr

Pressure ..... 550 kPa

Maximum suction head at pump inlet ..... 3 m

Maximum static pressure head ..... 4 m

Fuel inlet temperature to be less than ..... 55 °C

Governor type ..... electronic

Governing to ..... ISO 8528-5 class G3 steady state

### Fuel filtration level

-primary ..... 10 µm

-secondary ..... 2 µm

### Fuel consumption

Designation	Fuel consumption calculated on nett rated powers	
	g/kWh	litres/hr
	1800 rev/min	
Standby	222	126
Prime + 10%	222	126
Prime	225	113
At 75% of Prime	245	93
At 50% of Prime	267	67

## Induction system

### Maximum air intake restriction

- clean filter ..... 3,7 kPa
- dirty filter ..... 6,2 kPa
- air filter type ..... paper element 457 mm diameter

## Lubrication system

The recommended SAE viscosity is a multigrade oil (15W40) which adequately meets the specifications of API CI4

- Total system capacity ..... 62,0 litres
- Maximum sump capacity ..... 53,0 litres
- Minimum sump capacity ..... 45,0 litres

### Lubricating oil pressure

- at rated speed ..... 420 kPa
- Nominal (minimum) ..... 200 kPa
- Oil relief valve opens..... 620 kPa
- Oil filter screen spacing... 30 µm
- Sump drain plug tapping size ..... M24
- Oil pump speed and drive method . . . . . 1,16 x engine speed, gear
- Oil flow ..... 3,5 litres/sec
- Oil consumption at full load rated speed  
(as a percentage of fuel consumption)..... 0,1%
- Oil temperature (in rail)
- maximum continuous operation ..... 114 °C

### Normal operating angles

- front and rear ..... 7°
- side tilt..... 7°

## Recommended SAE viscosity

A single or multigrade oil must be used which conforms API CI4 or ACEA E5.

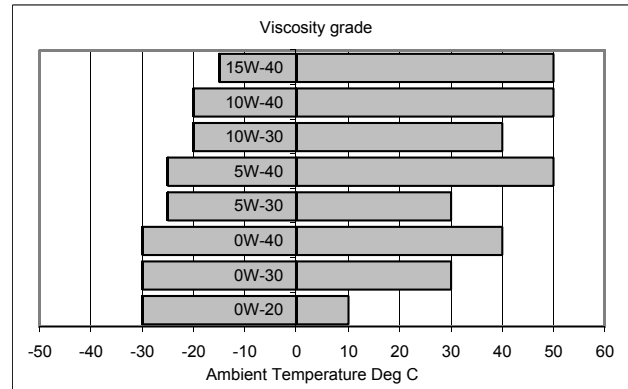

## Mountings

- Maximum static bending moment at rear face of block. .... 1356 Nm

## Centre of gravity (bare dry engine)

- forward of rear face of cylinder block ..... 570 mm
- above crankshaft centre line ..... 240 mm

## Engine management system

Full electronic engine management system controlling:

- speed governing
- air / fuel ratio
- start / stop sequence
- engine protection and diagnostics

**Typical load acceptance**

Model / Engine speed	Initial Load Acceptance When engine reaches rated speed (15 seconds maximum after engine starts to crank)				2nd Load Application Immediately after engine has recovered to rated speed (5 seconds after initial load application)			
	Prime Power %	Load kWm (kWe) Nett	Transient Frequency Deviation %	Frequency recovery time seconds	Prime Power %	Load kWm (kWe) Nett	Transient Frequency Deviation %	Frequency recovery time seconds
1800 rev/min	65	266	≤10	5	60	245	≤10	5

The above figures were obtained under test conditions as follows:

- Engine block temperature ..... 45 °C
- Ambient temperature ..... 15 °C
- Governing mode ..... Isochronous
- Alternator inertia ..... 8 kgm<sup>2</sup>
- Under frequency roll off (UFRO) point set to ..... 1 Hz below rated frequency
- UFRO rate set to ..... 2 % voltage / 1% frequency
- LAM on / off ..... off

All tests were conducted using an engine installed and serviced to Perkins Engines Company Limited recommendations.

The applied load is a percentage of generator electrical output, using alternator efficiencies as published in the general installation section of this Technical Data Sheet.

**The information given on this Technical Data Sheet is for standard ratings only. For ratings other than those shown, please contact Perkins Engines Company Limited, Stafford.**

**The information given in this document is for guidance only.**



Perkins Engines Company Limited  
 Peterborough PE1 5NA United Kingdom  
 Telephone +44 (0) 1733 583000  
 Fax +44 (0) 1733 582240  
 www.perkins.com

Distributed by

All information in the document is substantially correct at the time of printing but may be subsequently altered by the company.