

DIMENSIONAL DRAWINGS

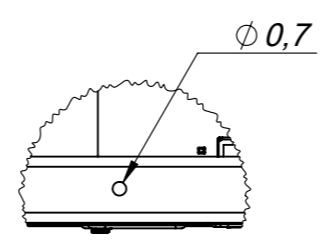

ENGINES
1106D-E70TAG2
1106D-E70TAG3
1106D-E70TAG4
1106D-E70TAG5

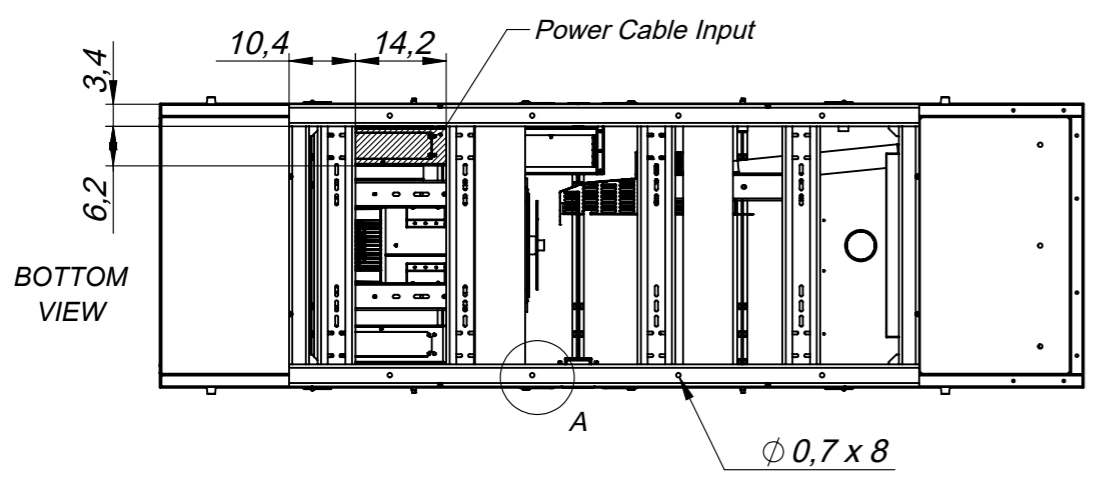
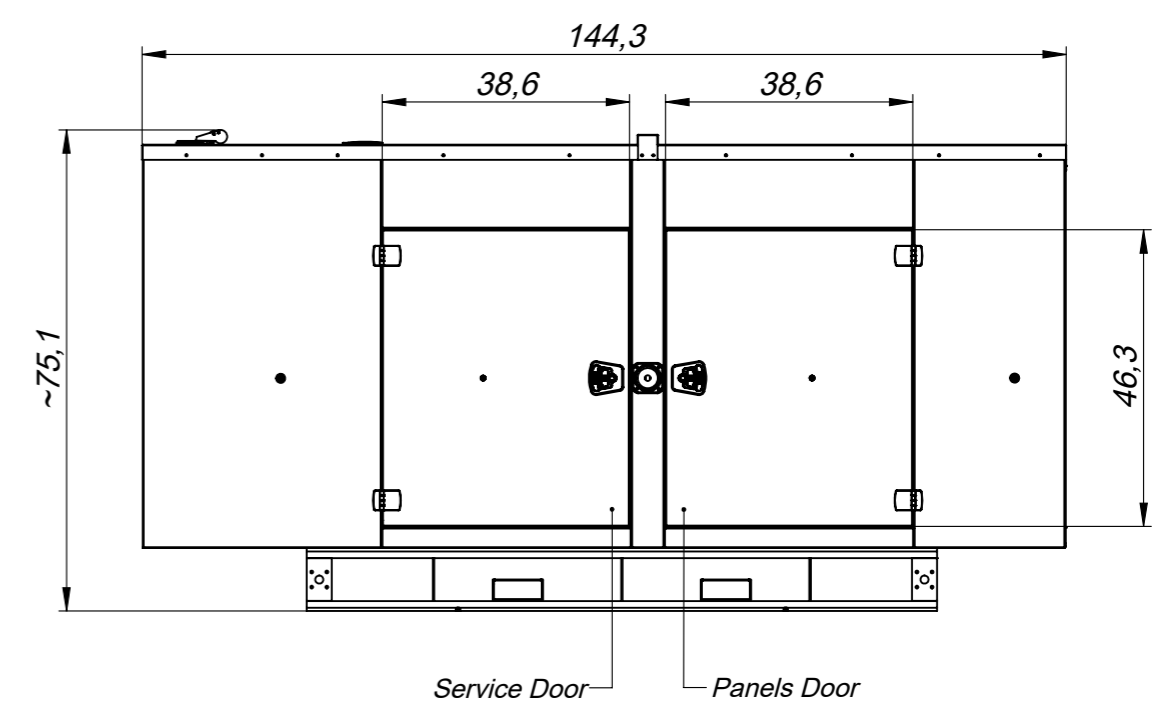
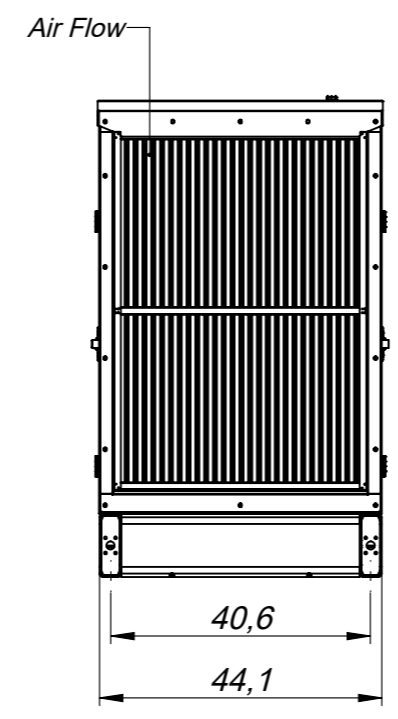
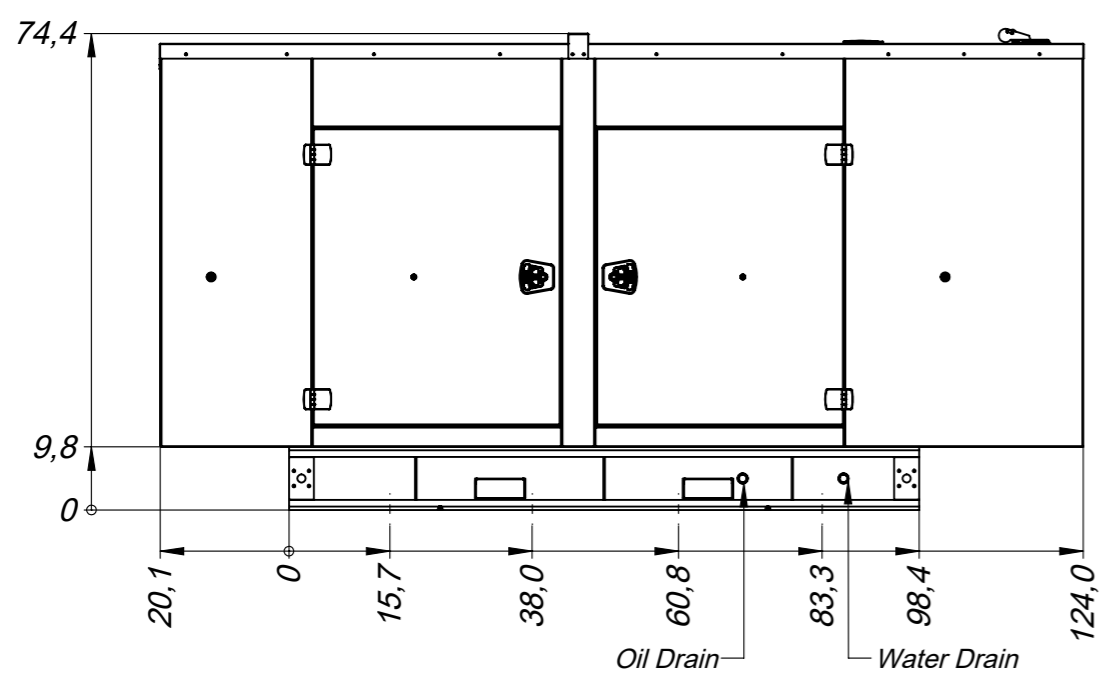
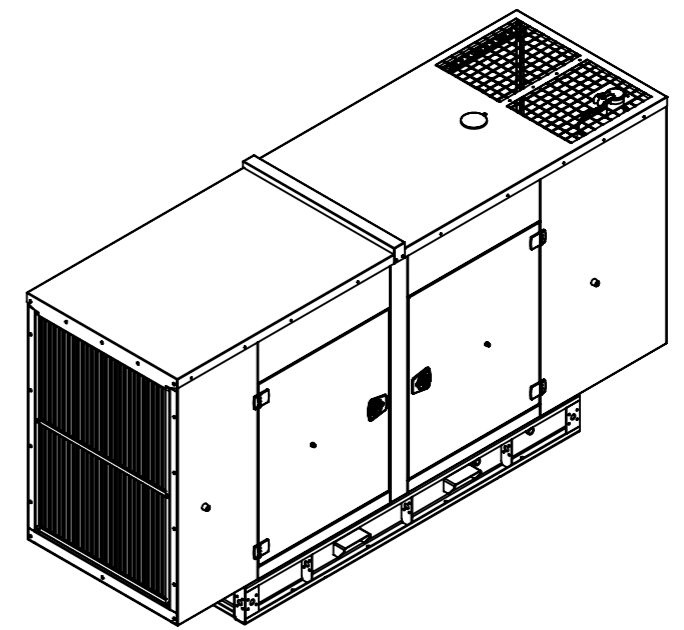
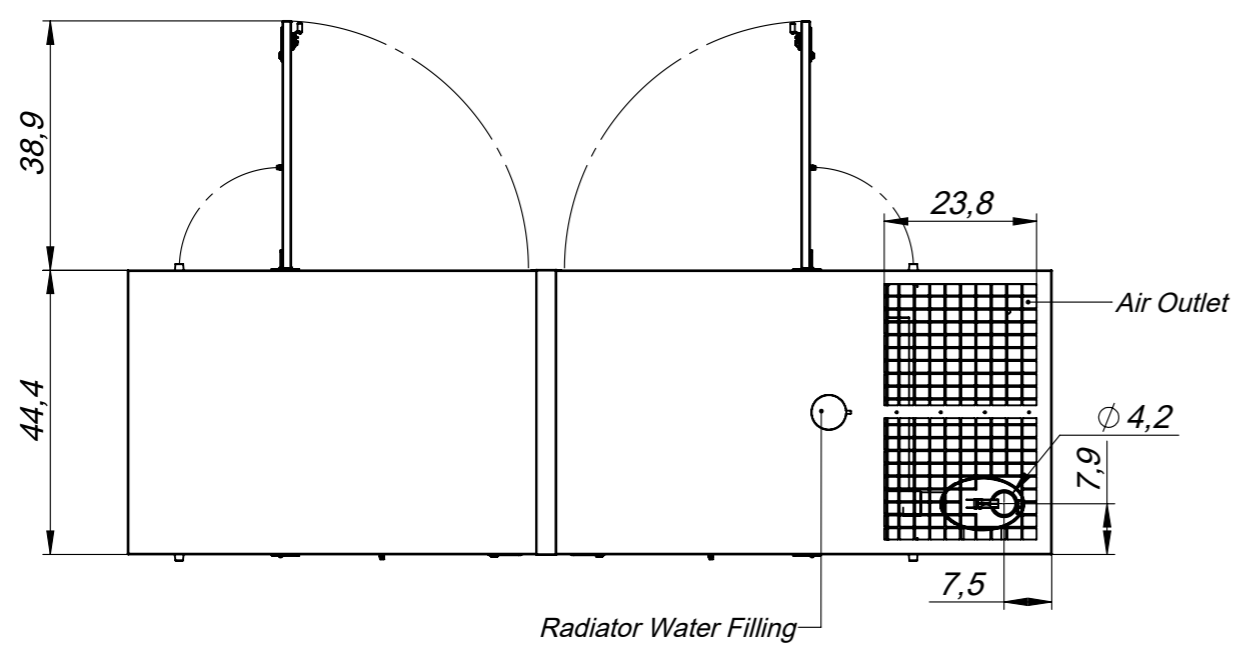

DETAIL A
SCALE 1 : 10

Do not take measurements based on the drawing.
This illustration may be changed without notice and is for informational purposes only.

	Tolerances	Name	Date	Document No
	N / A	Melih Gülşen	11-01-2024	SM-240185455
	1. Projection Method	Checked	-	Part Code
		Approval	-	-
* _ *	Paper Size	Scale	Order No	Rev. No
	A3	1:30	-	-
				Title
				DRAFT

ENGINES
1106D-E70TAG2
1106D-E70TAG3
1106D-E70TAG4
1106D-E70TAG5

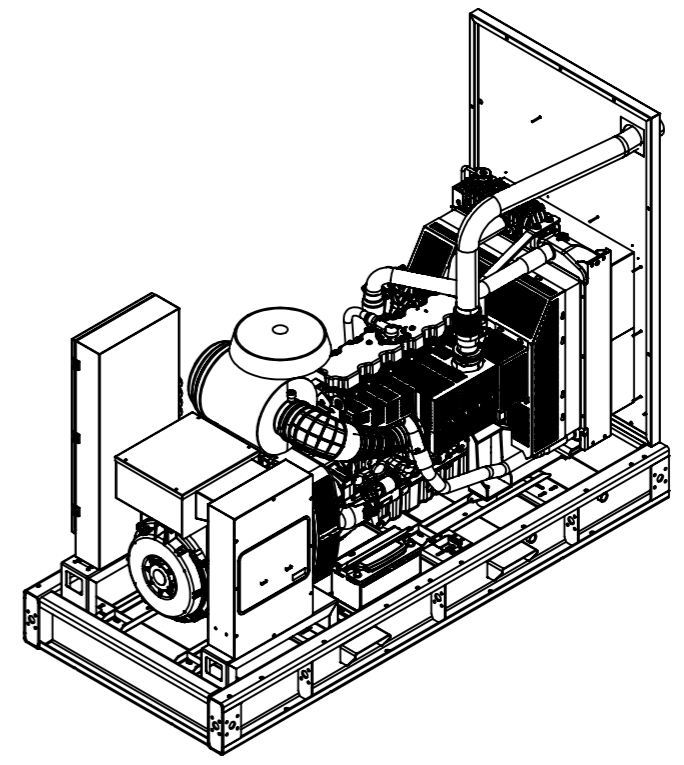
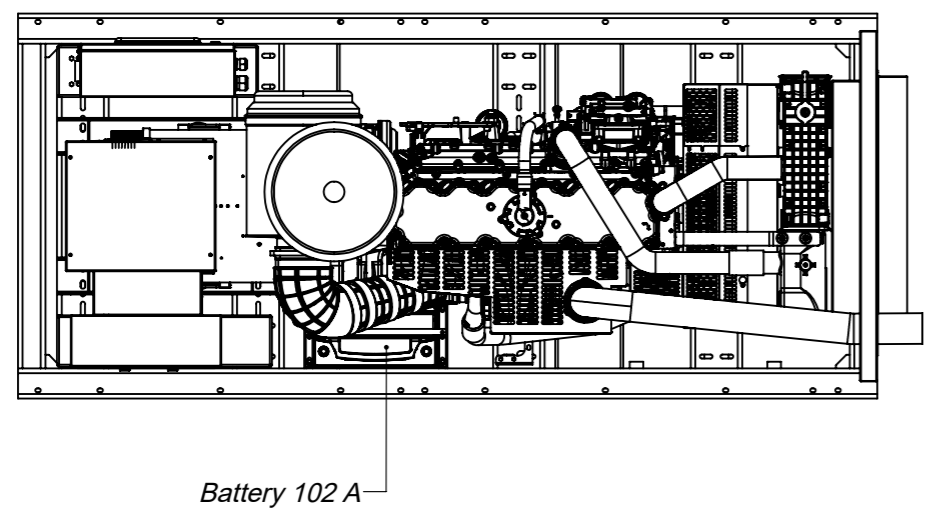
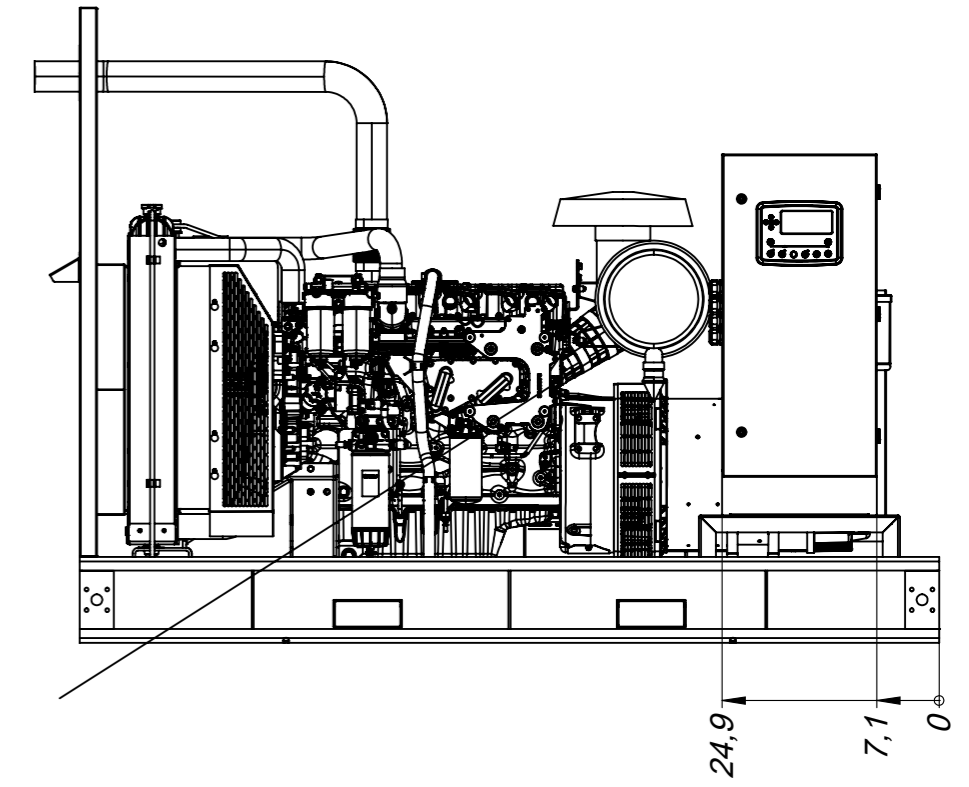
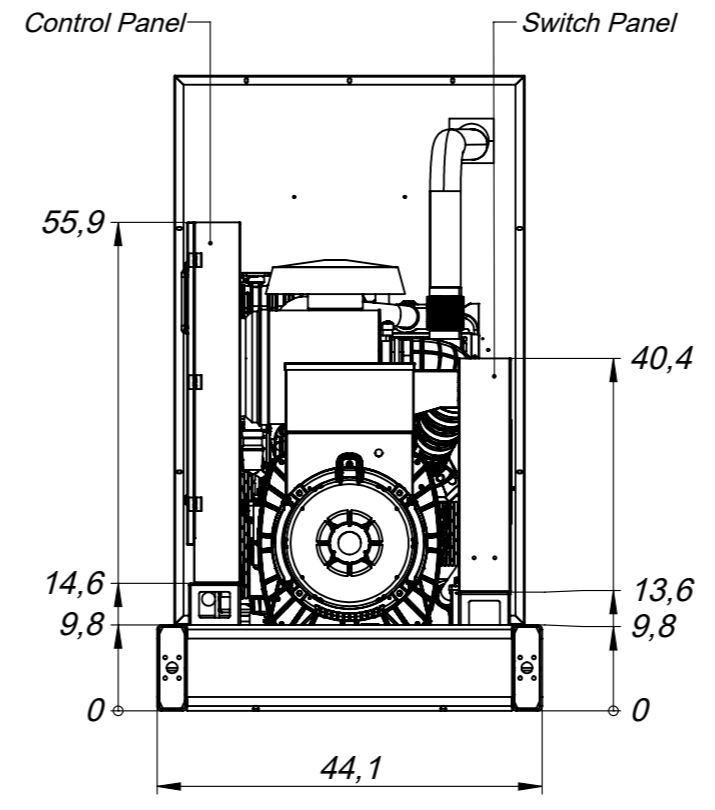
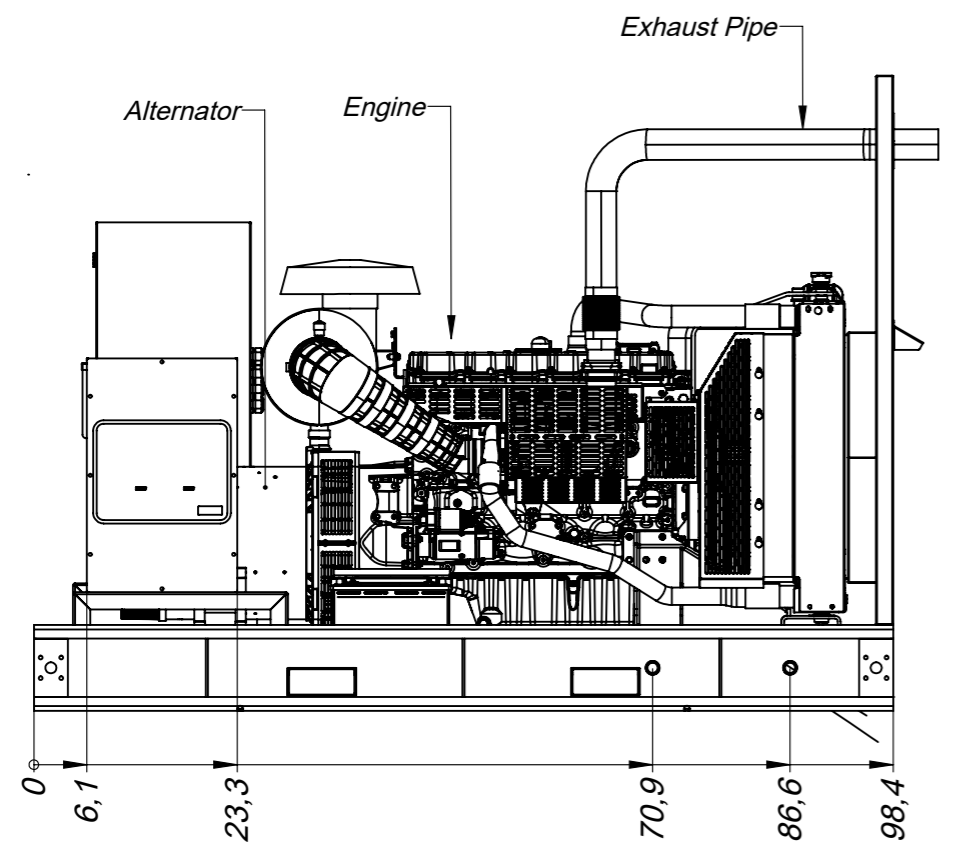

Do not take measurements based on the drawing.
This illustration may be changed without notice and is for informational purposes only.

	Tolerances	Name	Date	Document No
	N / A	Drawn melih.gulsen	16-11-2023	SM-231184655
	1. Projection Method 	Checked Melih Gülşen	27-12-2023	Part Code
		Approval Goktug Ada	27-12-2023	-
* _ *	Paper Size	Scale	Order No	Rev. No
	A3	1:22	-	R01
				Title
				DRAFT

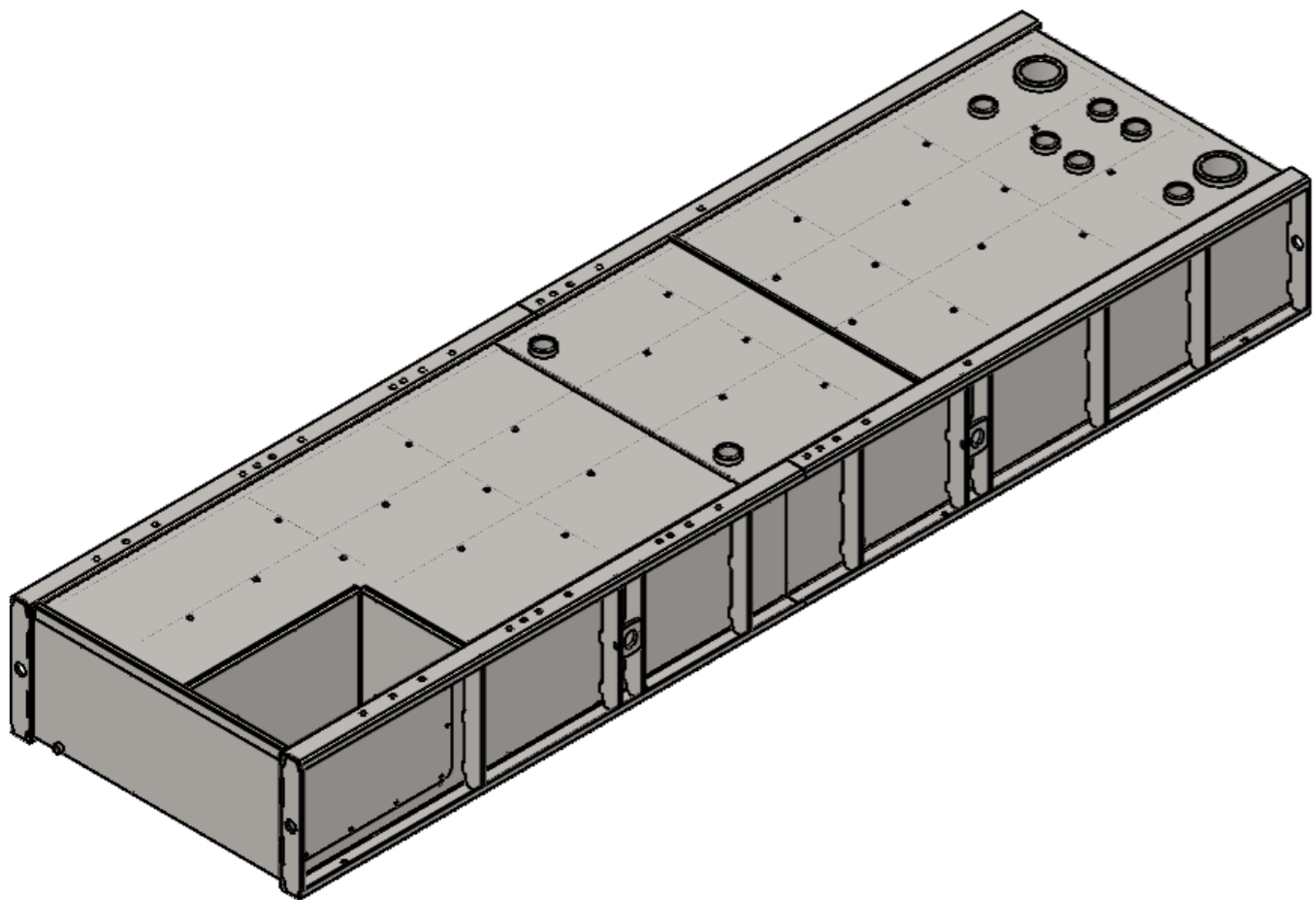
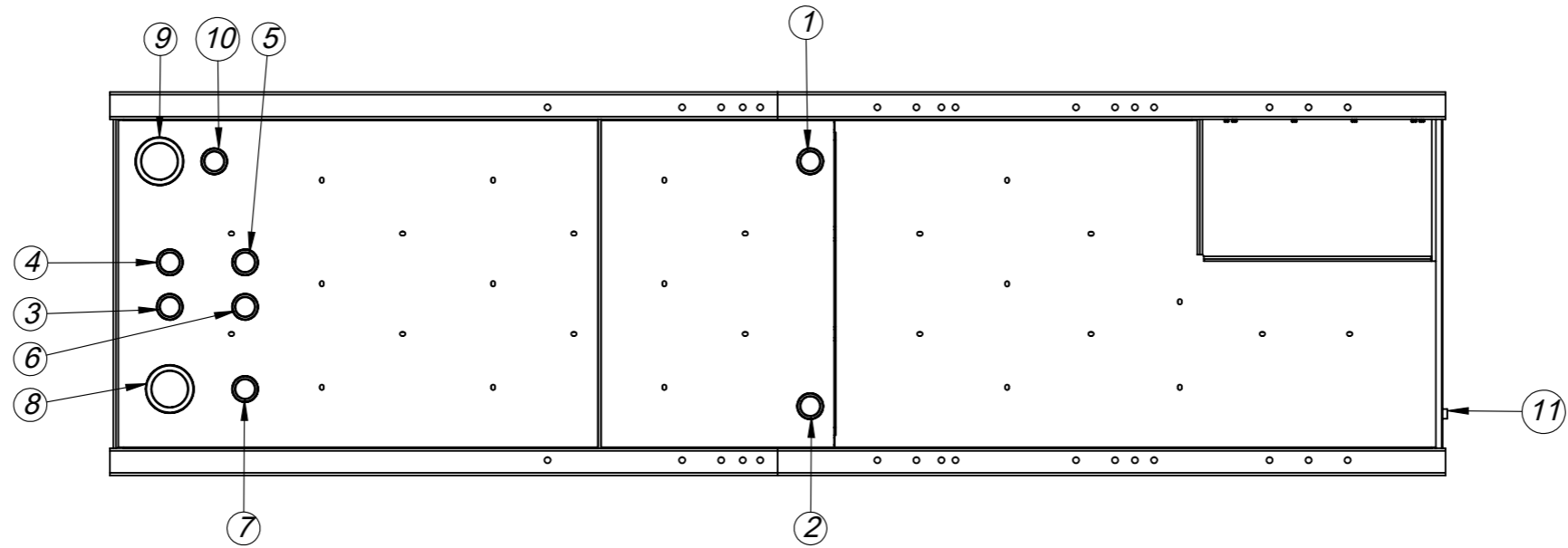
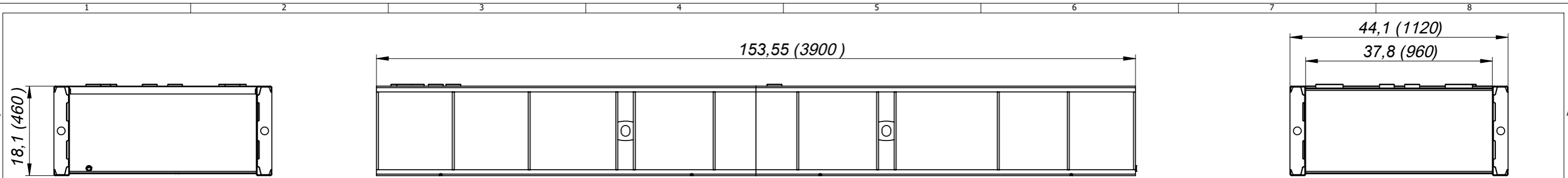

UL 142
GROUP-3 (300 GALLON)
NOTES (PRIMARY STEEL TANK)
Thickness of tank;
Lifting Lug & Support Brackets: 10mm
Primary Tank: 4mm
Secondary Tank: 4mm
TANK SPECIFICATION
Shell Material: S235JR
Coupling Material: ASTM A106

MARK	QUANTITY	SIZE	SPECIFICATION	DESCRIPTION
11	1	1/2" (NPT)	ASTM A105	Secondary Tank Drain
10	1	2" (NPT)	ASTM A105	Leak Detection Coupling
9	1	4" (NPT)	ASTM A105	Secondary Tank E. Vent
8	1	4" (NPT)	ASTM A105	Primary Tank E. Vent
7	1	2" (NPT)	ASTM A105	Normal Vent
6	1	2" (NPT)	ASTM A105	Fuel Low Level Sensor
5	1	2" (NPT)	ASTM A105	Fuel High Level Sensor
4	1	2" (NPT)	ASTM A105	Automatic Tank Gauge
3	1	2" (NPT)	ASTM A105	Filling Coupling
2	1	2" (NPT)	ASTM A105	Return Coupling
1	1	2" (NPT)	ASTM A105	Suction Coupling

TEKSAN	Tolerances	Name	Date	Document No	
	ISO 2768	Yasin Parlak	23-10-2023	SM-231084311	
	1. Projection Method 	Checked	Ferhat Nergis	30-11-2023	Part Code
		Approval	Murat Uysal	01-12-2023	-
_	Paper Size	Scale	Order No	Rev. No	
	A3	1:20	-	R00	
				Title	
				DRAFT	

Do not take measurements based on the drawing.
This illustration may be changed without notice and is for informational purposes only.

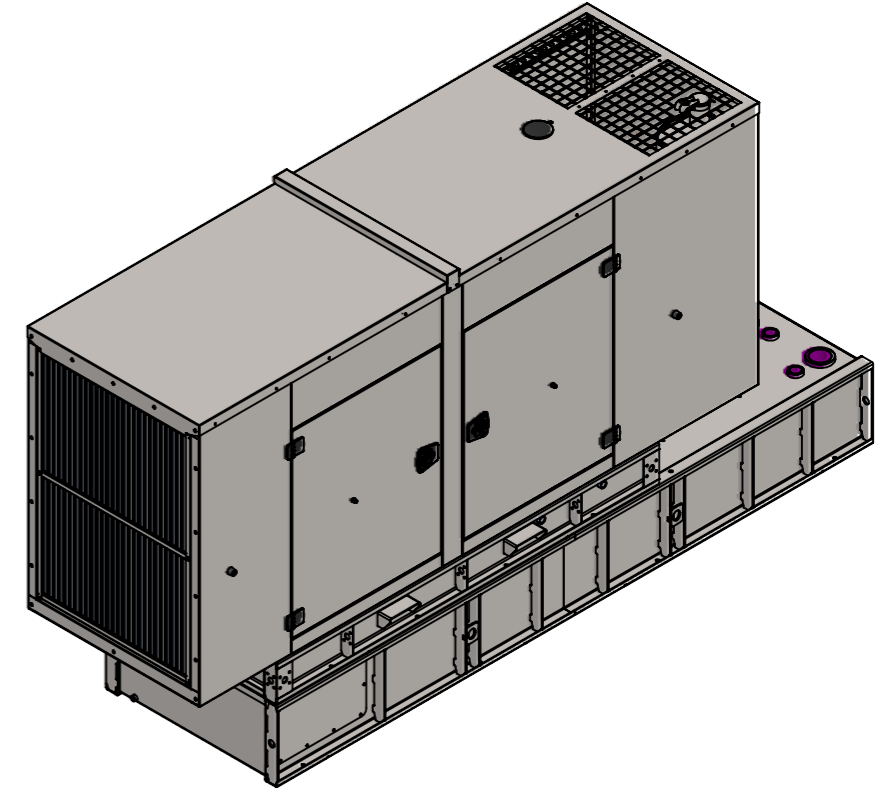
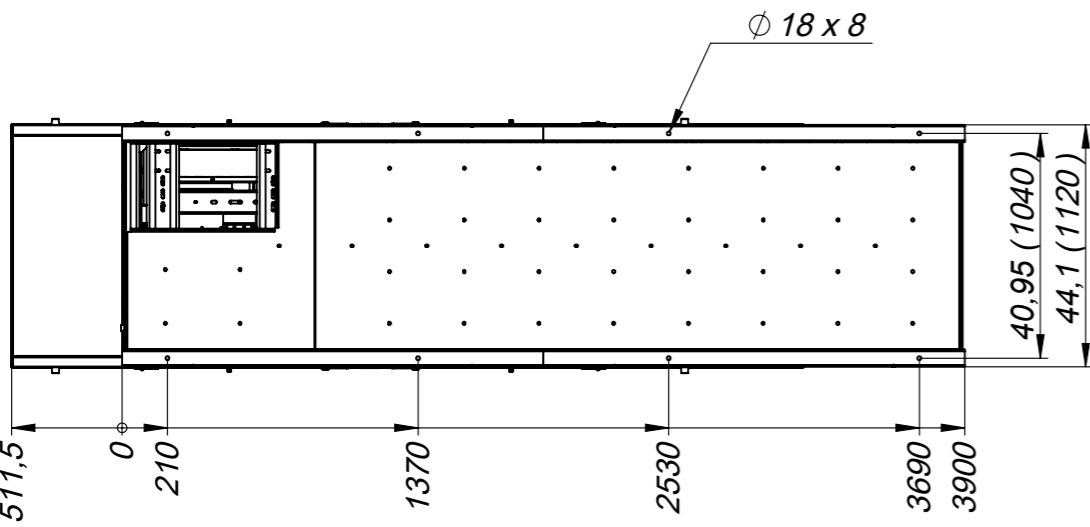
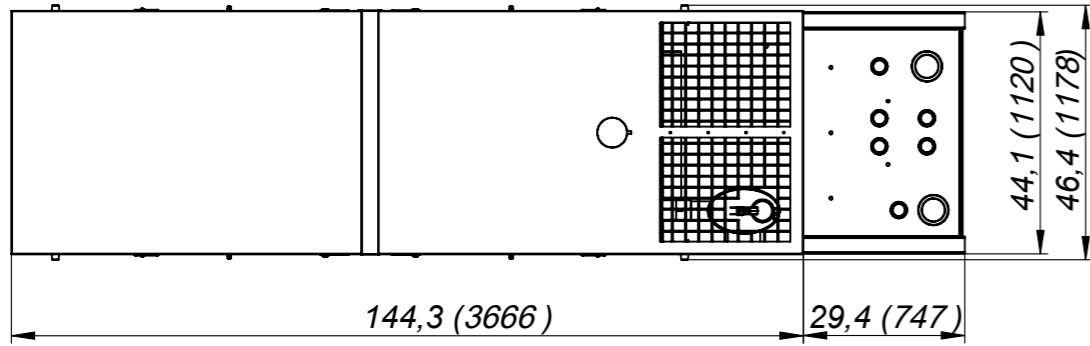
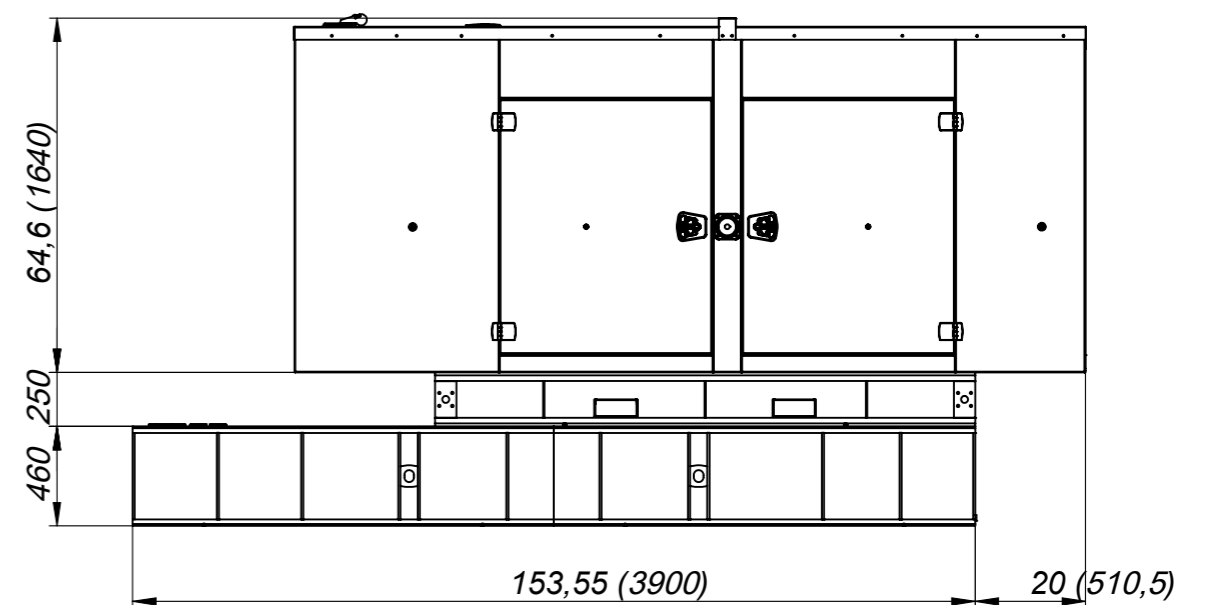
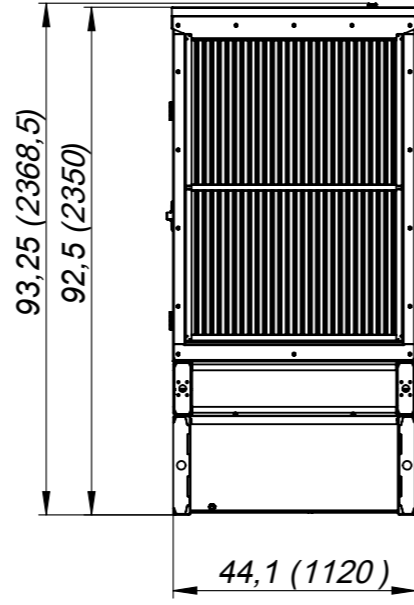
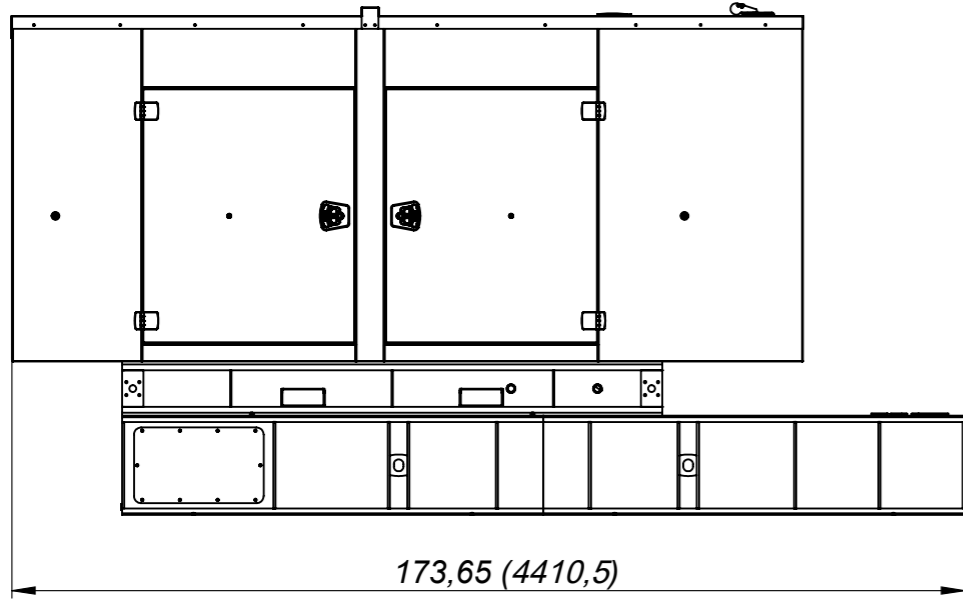

Do not take measurements based on the drawing.
This illustration may be changed without notice and is for informational purposes only.

TEKSAN	Toleranslar	İsim	Tarih	Ağırlık	Rev. No	Çizim No	SM-231184604
	ISO 2768	Çizen	14-11-2023	3169898.14 gr.	R00(Ç)		
* _ *	İzdüşümü Metodu	Kontrol	-	Yüzey Alanı	Kalınlık	Stok Kodu	-
	Onay	Sayfa	Ölçek	Malzeme	Sipariş No	Ebatlar	Tanım:
	A3	1:35					DRAFT