

TJT4F92DW SUBMITTAL DOCUMENTS

 *TEKSAN*

TEKSAN, which aims to deliver uninterrupted power solutions to the people through sustainable improvement and innovation, designs and installs high quality diesel, natural and biogas driven generator sets, mobile lighting towers, gasoline generators, cogeneration-trigeneration solutions and hybrid power systems that exceed the expectations of the customers.

For more than quarter century, thanks to its solid experience and engineering know-how, TEKSAN has been providing tailormade power solutions that can efficiently operate even under the most challenging conditions for major international projects such as constructions, telecommunications, data centers, shopping centers, hotels, residential buildings, supermarkets, sport centers, mining facilities, hospitals, research centers, educational institutions, and industrial plants all around the world.

Today, thanks to its high-quality generator sets approved with international quality certifications which are made of world's top engine brands coupled to well know alternators to meet projects' requirements of different output ranges, and fast and effective after-sales technical support and maintenance services in more than 130 countries with two factories and one R&D Center.

TEKSAN is always your reliable power solutions partner whenever and wherever you need.



TEKSAN USA, which is a subsidiary of TEKSAN Generator, aims to deliver uninterrupted power solutions to the people through sustainable improvement and innovation, designs and installs high quality diesel, natural and biogas driven generator sets, mobile lighting towers, gasoline generators, cogeneration-trigeneration solutions and hybrid power systems that exceed the expectations of the customers.

TJT4F92DW

Industrial Diesel Generator Sets

EPA Certified for Mobile / Stationary Prime Applications

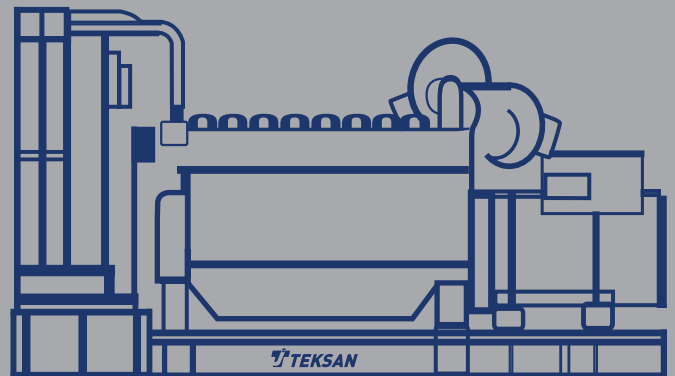

Genset Standby Power Rating

Voltage	208/120V	480/277V	240/120V	Multi Voltage		
				208/120V	480/277V	240/120V
Phase	3	3	1	3	3	1
Pf	0,8	0,8	1	0,8	0,8	1
Alternator Model	LSA44.3S5	LSA44.3S4	LSA44.3S5	LSA 44.3 M6		
Temp Rise	125 / 40 °C	125 / 40 °C	125 / 40 °C	125 / 40 °C		
Connection	12 Leads PS	12 Leads SS	12 Leads DD	Voltage Selector Switch		
Standby Power kW/kVA	82/102	81/101	65/65	82/102	82/102	76/76
Current	284A	122A	271A	284A	123A	317A
Prime Power kW/kVA	73/92	73/91	65/65	73/92	73/92	73/73
Current	255A	110A	271A	255A	110A	306A

Continuous Power

The maximum power which a generating set is capable of delivering continuously whilst supplying a constant electrical load. Average load can be 100%. The generator must not be overloaded.

Prime Power

The maximum power which a generating set is capable of delivering continuously whilst supplying a variable electrical load. Average load should be 70%. The generator can be overloaded 10% for 1 hour per 12 hrs.

Standby Power

The max power available during a variable electrical power sequence, under the stated operating conditions, for which a generating set is capable of delivering in the event of a utility power outage or under test conditions for up to 200 hrs of operation per year under average of 70% load. Overloading isn't permissible.

Certifications & Standards

The Generator set is designed and manufactured in a facility certified to **ISO9001:2015, ISO14001:2015, ISO45001-2018** and **ISO10002:2014 standards.**

The generator set, with its components, are **prototype tested**, factory-built and production tested per UL standards.

Application Data - Engine

Engine		Fuel Consumption	
Manufacturer	Doosan	Standby Power (110% of Prime)	5.9 gal/h
Model	D34	Prime Power (100%)	5.3 gal/h
Number of Cylinders	4, Inline	DEF Consumption	7~8% of Diesel consumption
Cubic Capacity	0.900 gallon	Cooling System	
Bore x Stroke	3.86 in x 4.45 in	Cooling Method	Fresh water forced circulation
Aspiration	Turbocharged, air to air aftercooled	Total Coolant Capacity	3.20 gallons
Combustion Ratio	18.0:1	Water Pump	Centrifugal type driven by belt
Gross Engine Power - Standby	92 kW	Cooling Fan	Blower type, Ø18.11 (ATB 52°C)
Net Engine Power - Standby	88 kW	Water temperature	230 °F (max.)
Gross Engine Power - Prime	83 kW	Lubrication System	
Net Engine Power - Prime	79 kW	Oil Filter	Full flow, cartridge type
Rated rpm	1800	Total lubricating capacity	3.33 gallons
Emission	Tier 4 Final	Lubricating Oil	10W30/40(API CJ-4 / ACEA E6, E9)
		Max Oil Temperature	275 °F at main oil gallery
Electrical System		Engineering Data	
Starting Motor Voltage	12V	Water Flow	23.78 gallons/min
Battery Charging Alternator	110A	Air Flow	26443.6 gallons/min
Battery Qty, CCA Rating	100 Ah, 750CCA	Exhaust Gas Temperature	1382 °F
		Max. Intake Permission Restrictions	6.5 kPa dirty filter
Fuel System		Max. Exhaust Permission Restrictions	50 kPa
Fuel Injection	Bosch		
Fuel Pump	Common Rail		
Governor Type	ECU		
Fuel Filter	Full flow, cartridge type		

Application Data - Alternator

Manufacturer	Leroy Somer					
Type	4 Poles, Brushless					
Protection	IP 23					
Voltage Regulation	± 0.25%					
One Step Load Acceptance	100% of rated load					
Bearing	Single					
THD in Linear Load	< 5%					
Waveform: NEMA TIF	< 50					
Altitude	≤ 1000 meters					
Over Speed	2250 rpm					
AVR	D350					
Genset Voltage	208/120V	480/277V	240/120V	208/120V	480/277V	240/120V
Alternator Model	LSA44.3S5	LSA44.3S4	LSA44.3S5	LSA44.3M6		
Phase / Leads / Connection	3 / 12 / PS	3 / 12 / SS	1 / 12 / DD	Multi Voltage Selector - 3/3/1		
P.F.	0,8	0,8	1	0,8	0,8	1
Power @ Temp Rise 125/40 °C	108kVA	113kVA	65kVA	135kVA	156kVA	76kVA
Power @ Temp Rise 105/40 °C	99kVA	103kVA	59kVA	123kVA	142kVA	69kVA
Efficiency @ 100% load	92,90%	92,40%	92,70%	91,68%	91,60%	90,00%
skVA @ 30% Voltage Dip (P.F. = 0.6)	315kVA	420kVA	-	330kVA	440kVA	-

Application Data - Circuit Breaker

Genset Voltage	208/120V	480/277V	240/120V	Multi Voltage
ABB (80% Rated) Breaker	300A	125A	300A	400A

Control Panel

Manufacturer	DSE - Deep Sea Electronics
Model	7310 MKII
DC Supply	8 to 35V Continuous
Generator Voltage Range (Ph-Ph)	26V to 719V AC
Generator Frequency Range	3,5Hz to 75Hz
Standards	BS EN 61000-6-2, BS EN 61000-6-4, BS EN 60950, BS EN 60529 BS EN 60068-2-1, BS EN 60068-2-2 BS EN 60068-2-6, BS EN 60068-2-30 BS EN 60068-2-78, BS EN 60068-2-27



Key Features

- License free PC software
- 4-Line back-lit LCD text display
- Five key menu navigation
- LCD Alarm Indication
- DSENet expansion compatibility
- Internal PLC editor
- Protection disable feature
- Data logging facility
- Fully configurable via PC
- Front panel configuration
- Power safe mode
- 6 configurable DC outputs
- 2 configurable volt free relay outputs
- 6 configurable analogue/digital inputs
- 8 configurable digital inputs
- Configurable 5 stage dummy load and load shedding outputs
- Backed up real time clock
- Fuel usage monitor and low fuel level alarms
- Remote SCADA monitoring via DSE Configuration Suite PC Software
- Advanced SMS messaging (additional external model required)
- Start & Stop capability via SMS messaging
- Configurable event log (250)
- Multiple date and time scheduler

Protections

- ✓ Gen. Voltage – under / over
- ✓ Gen. Freq. – under / over
- ✓ Engine Speed – under / over
- ✓ Engine Oil Pressure – low
- ✓ Engine Temp – low / high
- ✓ Battery Voltage – low / high
- ✓ Weak Battery
- ✓ Fail to Start / Stop
- ✓ Charge Alternator Fail
- ✓ Over Current & Load (kW/kVAR)
- ✓ Unbalanced Load
- ✓ Independent Earth Fault
- ✓ Reverse Power
- ✓ Loss of Speed Signal

Instruments

- ✓ Gen. Voltage (L-L/L-N)
- ✓ Gen. Frequency
- ✓ Engine speed
- ✓ Oil Pressure
- ✓ Water Temperature
- ✓ Battery Voltage
- ✓ Run Time
- ✓ Phase Sequence
- ✓ Power monitoring (kWh/kVAh/kVArh)
- ✓ Power (kWh/kVAh/kVArh)
- ✓ Power Factor
- ✓ Generator Current
- ✓ Generator Load (%)
- ✓ Earth Current

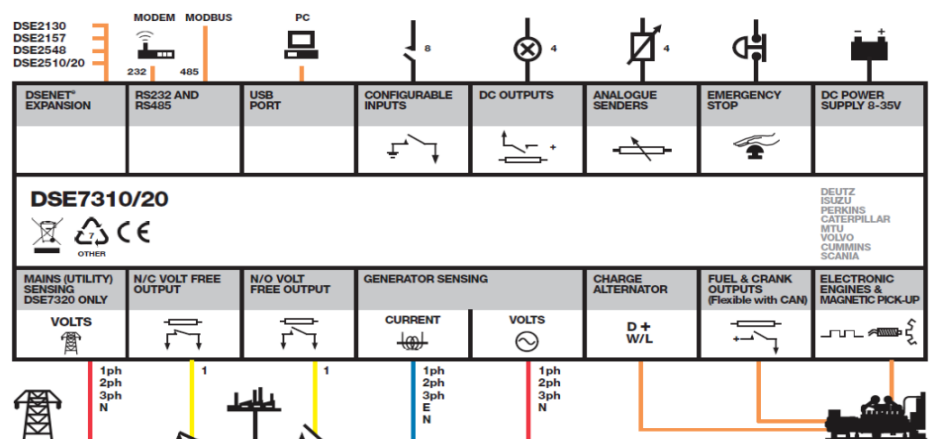

TJT4F92DW

Industrial Diesel Generator Sets



Dimensions, Weight & Sound Data

Enclosed Genset Data

L (inches)	W (inches)	H (inches)	Weight (lbs)
122"	44.5"	80.9"	5750

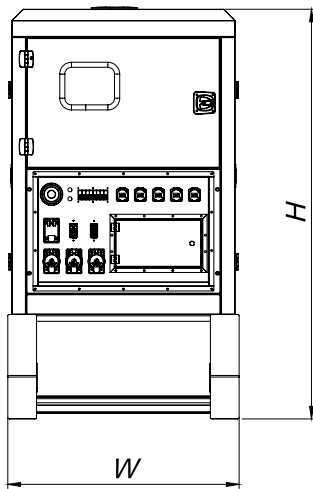

Integral Base Tank / DEF Tank

Sound Level	Run Time	Tank Capacity	DEF Capacity
68dBA*	26h	159gal / 600lt	7.9gal / 30lt

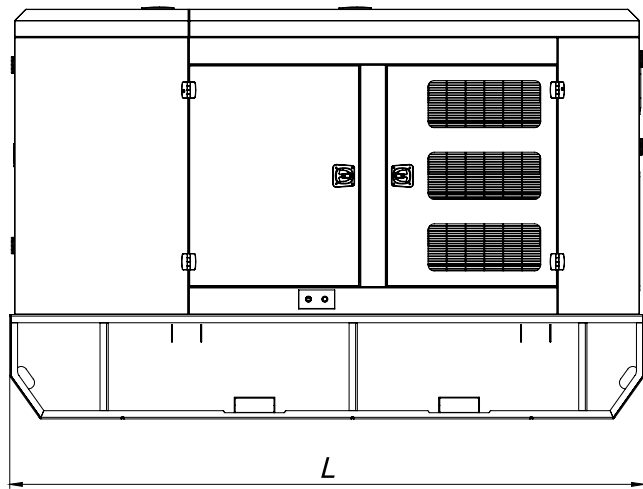

Genset w / Trailer Data

L (inches)	W (inches)	H (inches)	Weight (lbs)
185"	90"	107"	7350

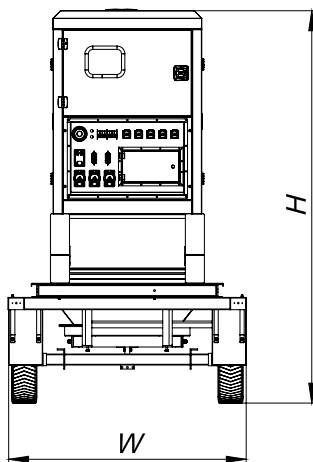

Integral Base Tank / DEF Tank

Sound Level	Run Time	Tank Capacity	DEF Capacity
68dBA*	26h	159gal / 600lt	7.9gal / 30lt

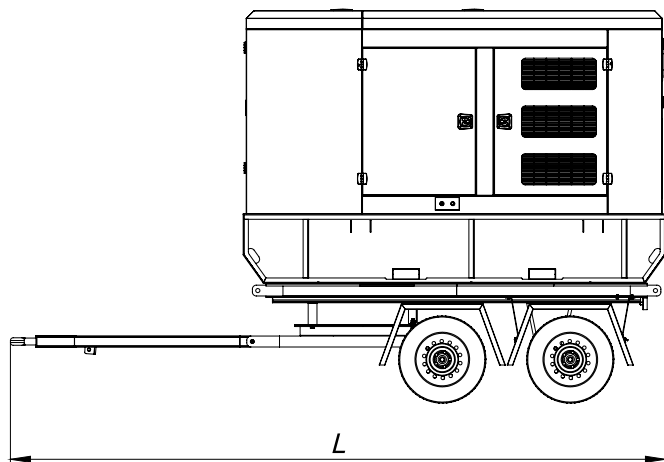

*All measurements are approximate and for estimation purposes only. Weights are without fuel in tank. Sound levels measured at 23ft (7m) and does not account for ambient site conditions.

Standard Features & Accessories

General

- Galvennealed Steel Enclosure
- Heavy Duty Base Frame (110% Fluids Containment)
- Integrated 24h Double Wall Fuel Tank
- Fork pockets and transportation tie downs
- Rust Prevention Hardware (Latches/Hinges)
- Single Top Lifting Hook (Genset only)
- Locable Fuel Filling Cap on Enclosure
- Jacket Water Heater w/Isolation Valves
- DOC Catalysts / Silencer Mounted
- 3 Way Fuel Connection Valve
- Oil & Coolant Drain Extension
- Vibration Isolation Mounts

Electrical

- Three Position Voltage Selector Switch
- Main Line CB
- Battery Charger
- Voltage Adjust Rheostat

Convenience Panel

- (3)-50A 125/250VAC 3P4W Twist Lock CS6369
- 2-20A 120VAC Duplex GFCI Nema 5-20R
- Thumb Screw Terminals for 2-Wire Remote Start
- 15A 120VAC Male Receptacle Shore Power Connection
- (5)-400A Rated Female Cam Style Locking Receptacles
- (5)-400A Rated Lug Connection
- Emergency Stop Switch

Optional Accessories

General

- DOT Approved Trailer
- Trailer Mounted Spare Tire
- Trailer Mounted Tool Box
- Battery Disconnect Switch
- Crankcase Ventilation Filter

Electrical

- Low Fuel Level Switch & Alarm
- Fuel Level Monitoring via Controller
- Low Coolant Switch & Alarm
- Paralleling Controller Upgrade
- Motor Operated Breaker

DISTRIBUTED BY:





RENTAL SOLUTIONS





**WHENEVER YOU NEED POWER,
WE ARE ALWAYS WITH YOU...
SINCE 1994!**



Since 1994, Teksan has been delivering high quality tailormade solutions that are designed accordingly to your requirements with strong after-sales technical support and maintenance services anytime and anywhere you need uninterrupted power supply. When your company is moving further ahead rapidly on the road to success, you always feel our continuous support as your reliable power solutions partner.

Because Teksan is a member of your family...

WE DELIVER POWER TO THE WORLD



 **2** factories
60.000 sqm+
TOTAL PRODUCTION AREA

 **800+**
employees

 **15.000**
gensets
ANNUAL PRODUCTION CAPACITY

THE STRUCTURE OF A POWERFUL FUTURE

With our vision of being a global brand that makes a difference in the energy sector and our mission of being a reliable and innovative solution partner for a sustainable life, we keep producing power solutions for different sectors in more than 140 countries of the world and shape the future with our corporate values that at all times carry us forward!



HIGH PERFORMANCE TEKSAN RENTAL DIESEL GENSETS

- Gensets in different sizes from 36kVA up to 702kVA PRP at 60Hz, 3Ph
- Engine mounted radiator with vertical air discharge
- Starter motor and charge alternator
- Fuel tank equipped with 3 way valve for external fuel tank
- Set mounted digital controller, with convenience panel
- Heavy duty steel base frame with integral fuel tank, forklift pockets
- Enhanced product safety for generating sets and users (safe connection points, circuit breakers, forklift points, etc...)
- Easy and safe access for service operations
- Improved performance against extreme environmental conditions
- ISO 8528-5 standard, provides a high starting and loading capacity for critical applications best in noise levels. Thanks to the robust enclosure (sound proof canopy or container)
- Convenient quick connect powerlocks and busbar connection
- Long service and maintenance intervals with maximum engine running time



QUICK-COUPLING FUEL CONNECTION



CONVENIENCE PANEL



UP TO 24 HOURS FUEL TANK

Our specific designed fuel tank provides with up to 24+ hours running time along as well as easy access and hassle free fuel filling.



3-WAY VALVE



BATTERY ISOLATOR SWITCH



VOLTAGE SELECTOR SWITCH

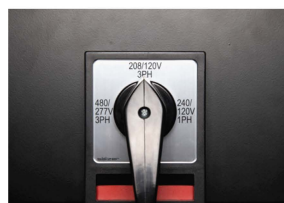



USABILITY

- Dedicated accesses
- Quick connect powerlocks and busbar
- Radiator access door



DURABILITY

- Large and strong banded frame (retention fuel tank capacity for 110% of generator liquids, up to 24+ hours autonomy fuel tank)
- Strong and compact design
- Double impregnation alternator
- Waterproof wiring and connectors



SAFETY

- Door retainers
- Large engine access doors with anti-opening lock system to avoid opening during transport
- Water and dust proof control power box integrating electronic and electric devices



HANDLING

- Integrated single top lifting point
- Lifting points on the base frame















MAINTENANCE

- Enclosure doors with increased insulation thickness and high acoustic performance who designed to facilitate the access to engine and alternator
- Fuel pre filter
- Manual oil drain pump
- Door access for an easy cleaning of the radiator
- External fuel filling (quick couplink)
- Three way fuel valve



- | | |
|-------------------------------------|------------------------------------|
| 1 CONVENIENCE PANEL | 7 EXHAUST OUTLET |
| 2 TOW EYE | 8 ACOUSTIC ENCLOSURE DOORS |
| 3 CONTROL PANEL | 9 EXTERNAL FUEL QUICK CONNECTORS |
| 4 SOUND AND WEATHER PROOF ENCLOSURE | 10 TRAILER MOUNTING HOLES |
| 5 RADIATOR FILLING | 11 FORKLIFT POCKETS |
| 6 HOT AIR OUTLET | 12 AEROACUSTIC AIR IN TAKE POCKETS |

60Hz RENTAL TIER 4F

60 Hz GENSET MODEL	480/277V AC		208/120V-3PH		240/120V-1PH		MANUFACTURER	ENGINE MODEL	GENERATOR MODEL	EMISSION CLASS	AFTERTREATMENT UNITS	DIMENSIONS (inches)			Total Weight of Genset (lbs)	Fuel Tank Capacity (gal)	Fuel Tank Capacity (h)	Fuel Consumption (gal/h) 100%	DEF Tank Capacity (gal)	DEF Tank Capacity (hour) (100%)
	STAND-BY kVA	PRIME kVA	STAND-BY kVA	PRIME kVA	STAND-BY kVA	PRIME kVA						WIDTH	LENGTH	HEIGHT						
TJT4F36DW	41	36	40	36	28	28		D18	LSA 42.3 S5	TIER 4F	DOC	44,5	110,2	66,5	2862	71	27	2,6	N/A	N/A
TJT4F49DW	54	49	54	49	39	37		D24	LSA42.3L9	TIER 4F	DOC	44,5	110,2	66,5	2981	71	22	3,2	N/A	N/A
TJT4F92DW	102	92	102	92	76	73		D34	LSA44.3M6	TIER 4F	DOC+SCR	44,5	122,0	80,7	4626	159	29	5,4	7,93	14,6
TJT4F66JD	73	66	73	66	52	52		4045HFG04_68	LSA 44.3 S3	TIER 4F	DOC+SCR	44,5	122,0	80,7	4373	159	46	3,4	5,63	41,0
TJT4F78JD	86	78	86	78	65	62		4045HFG04_80	LSA 44.3 S5	TIER 4F	DOC+SCR	44,5	122,0	80,7	4454	159	39	4,0	5,63	32,4
TJT4F97JD	107	97	107	97	81	77		4045HFG04_99	LSA 44.3 M8	TIER 4F	DOC+SCR	44,5	122,0	80,7	4600	159	32	5,0	7,95	37,0
TJT4F128JD	141	128	141	128	95	95		4045HFG06_128	LSA44.3L10	TIER 4F	DOC+SCR	47,2	133,9	88,6	4837	185	28	6,6	7,95	30,3
TJT4F196JD	216	196	216	196	164	149		6068HFG05_192	LSA46.3S5	TIER4F	DOC+SCR	55,1	155,5	93,5	6216	277	27	10,4	7,95	23,8
TJT4F248JD	272	248	272	248	200	189		6068HFG06_240	LSA 46.3 M8*	TIER4F	DOC+SCR	65,0	189,0	96,5	8023	415	35	11,9	14,85	37,8
TJT4F325JD	358	325	358	325	231	231		6090HFG06_326	LSA 46.3 L11	TIER4F	DOC+SCR	65,0	189,0	96,5	9116	415	26	15,9	14,85	33,5
TJT4F510JD	560	510	560	510	TBA	TBA		6136CG440_505	LSA 47.3 M7	TIER 4F	DOC+SCR	78,7	213,8	100,4	11014	608	25	24,6	14,85	12,9
TJT4F625V	690	625	690	625	TBA	TBA		TWD1672GE	LSA47.3L10	TIER4F	SCR	78,7	213,8	100,4	13285	608	18	34,3	42,27	17,4
TJT4F700V	770	700	770	700	TBA	TBA		TWD1673GE	LSA49.3M6	TIER4F	SCR	78,7	213,8	100,4	13647	608	16	38,3	42,27	17,2

* Stand-by

ALWAYS AT YOUR SERVICE...

- Management of the service records on servers for proactive after sales services,
- Remote Monitoring and Management System,
- Call Center support.



UNIQUE AFTER SALES SERVICES AND TECHNICAL SUPPORT SOLUTIONS FOR YOUR PROJECTS;

- Free of charge site and power identification with our business partners or Teksan After Sales Services.
- Technical support and consultancy,
- Assembly and disassembly,
- Installation, commissioning,
- General maintenance services,
- Emergency calls,
- Modification, repair, revision*,
- Periodical maintenance services.



Thanks to our experienced engineering teams and technological infrastructure, we can meet your revision demands for all engine types and brands.

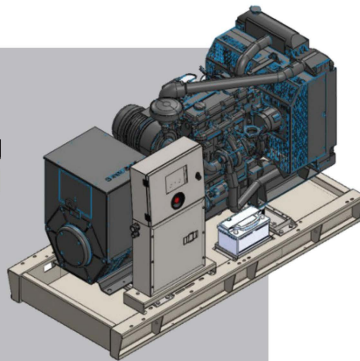

WE ARE YOUR EVERLASTING COMPANY



IN
140+
COUNTRIES



USA BRANCH OFFICE



+1 224 404 1274
www.teksanus.com
info@teksanus.com

TURKEY HEADQUARTER



+90 444 8576
www.teksan.com
info@teksan.com

The logo for TEKSAN USA, featuring a stylized 'T' icon followed by the text 'TEKSAN USA' in a bold, sans-serif font.

ENGINE DATASHEET



Frequency	Rpm	Gross Engine Output Standby / Prime kWm (ps)	Net Engine Output Standby / Prime kWm (ps)	Emission
50 Hz	1500	78(104) / 70(94)	75(100) / 67(90)	Stage V (DOC+DPF)
60 Hz	1800	92(124) / 83(112)	88(118) / 79(105)	Tier 4 Final (DOC only)



◆ General Engine Data

• Engine Type	In-line, 4-cycle
• Number of cylinders	4
• Displacement	3,409 liter
• Bore x Stroke	98 x 113 mm
• Compression ratio	18.0 : 1
• Firing order	1 - 3 - 4 - 2
• Aspiration	Turbocharged and air-to-air aftercooled
• Combustion System	Direct injection
• Rotation	Counter clockwise viewed from Flywheel
• Clutch	SAE#3 - 11/5" / SAE#4 - 10" (SAE J620)
• Dry weight	464 kg (with aftertreatment) 564 kg (with powerpack)
• Valve System Type	Over head valve
• Number of Valves	Intake 2, exhaust 2 per cylinder Hydraulic Valve Lash Adjust

◆ Engineering Data

• Water flow	75 liters/min @1,500 rpm 90 liters/min @1,800 rpm
• Heat rejection	- to coolant 11.3 kcal/sec @1,500 rpm 12.9 kcal/sec @1,800 rpm - to CAC 2.7 kcal/sec @1,500 rpm 3.6 kcal/sec @1,800 rpm
• Air flow	5,210 liter/min @1,500 rpm 6,150 liter/min @1,800 rpm
• Exhaust gas temp	750 °C ↓ @1,500 rpm & 1800 rpm
• Max. permission restrictions	- Intake system 3.0 kPa clean filter 6.5 kPa dirty filter - Exhaust system 50 kPa max.

◆ Electrical System

• Alternator	12V x 110A
• Voltage Regulator	Built-in type IC regulator
• Starting Motor	12V x 2.5kW
• Battery Voltage	12V
• Battery Capacity	100 Ah, 750CCA (recommended)
• Starting Aid	Glow plug

◆ Cooling System

• Cooling method	Fresh water forced circulation
• Water capacity	4.7 liter (engine only) 12.1 liter (with powerpack)
• Water pump	Centrifugal type driven by belt
• Cooling fan	Blower type, Ø460 (ATB 52°C)
• Water temperature	110°C (max.)

◆ Fuel System

• Injection pump	Bosch Common-rail Pump
• Governor	Controlled by ECU
• Fuel filter	Full flow, cartridge type
• Used fuel	Diesel fuel only
• Diesel consumption	204 g/kWh @1,500 rpm 206 g/kWh @1,800 rpm
• DEF Consumption	7~8% of Diesel consumption

◆ Lubrication System

• Oil filter	Full flow, cartridge type
• Oil pan capacity	High level 12.6 liters Low level 6.0 liters
• Angularity limit	35 deg all around
• Lubrication oil	10W30/40(API CJ-4 / ACEA E6, E9)
• Maximum oil temp	135°C at main oil gallery
• Lub oil pressure	Idle Speed : Min 100 kPa

◆ Engine Dimension

- Dimension (L×W×H) 936 × 744 × 1,140 mm (engine only)

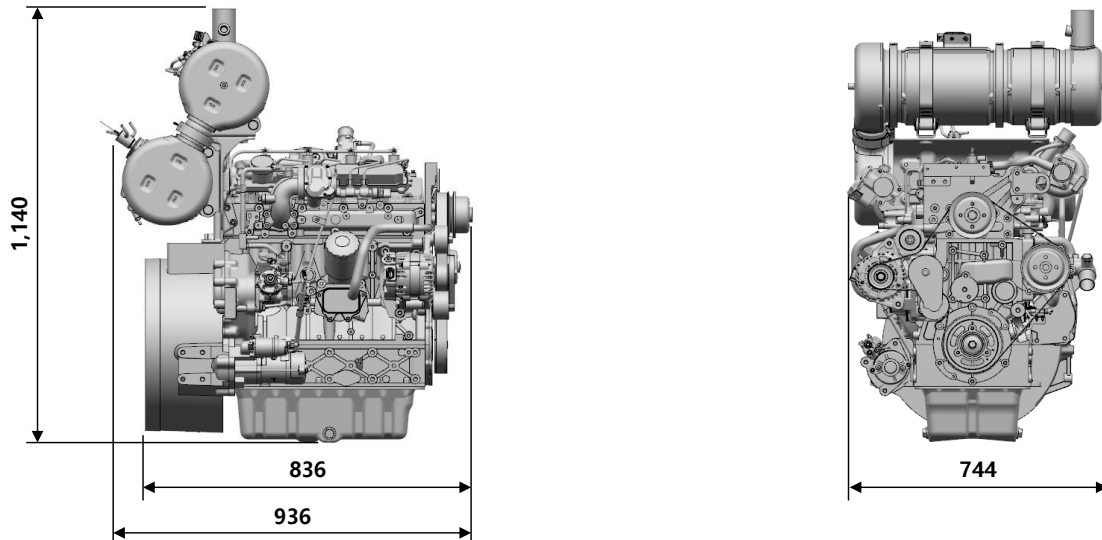

- Dimension (L×W×H) 1,276 × 790 × 1,181 mm (with power pack)

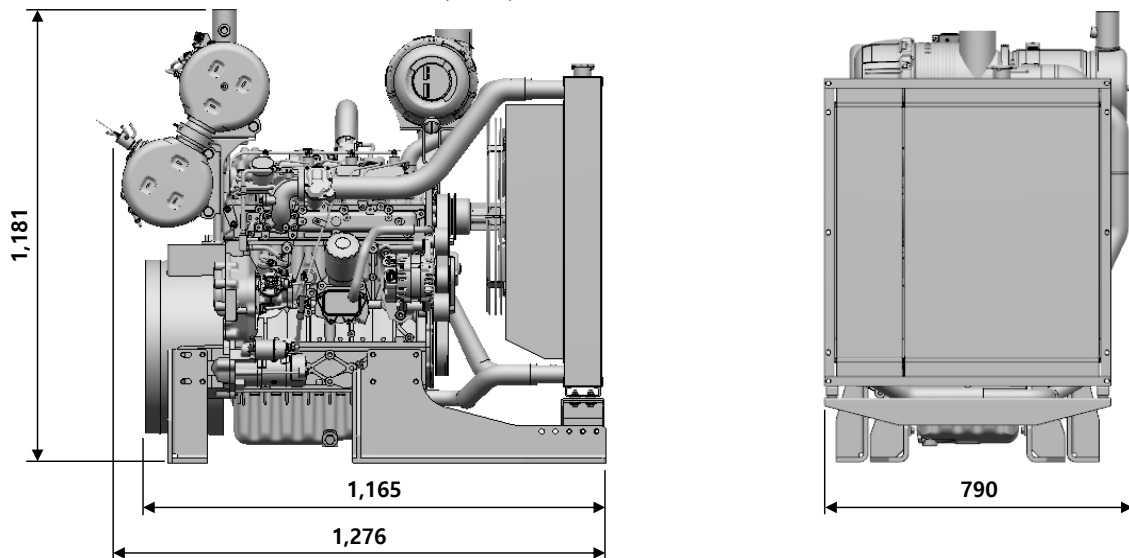

Ratings Definitions

The power ratings of Emergency Standby and Prime are in accordance with ISO 8528.

Fuel Stop power in accordance with ISO 3046.

Electric power (kWe) must be considered cooling fan loss, alternator efficiency, altitude derating and ambient temperature.

STANDBY POWER RATING is applicable for supplying emergency power for the duration of the utility power outage.

No overload capability is available for this rating. A standby rated engine should be sized for a maximum of an 80% average load factor and 200 hours of operation per year. This includes less than 25 hours per year at the Standby Power rating.

PRIME POWER RATING is available for an unlimited number of hours per year in variable load application. Variable load should not exceed a 70% average of the Prime Power rating during any operating period of 24 hours. The Total operating time at 100% Prime Power shall not exceed 500 hours per year. A 10% overload capability is available for a period of 1 hour withing a 12 hour period of operation. Total operating time at the 10% overload power shall not exceed 25 hours per year.

◆ Conversion Table

in. = mm x 0.0394	hp = PS x 0.98635	kW = 0.2388 kcal/s
PS = kW x 1.3596	lb = kg x 2.20462	lb/PS.h = g/kW.h x 0.00162
psi = kg/cm ² x 14.2233	lb/ft = N.m x 0.737	cfm = m ³ /min x 35.336
in ³ = lit. x 61.02	U.S. gal = lit. x 0.264	

Doosan Infracore Co., Ltd.

28th Floor, Doosan Tower, 275, Jangchungdan-ro, Jung-gu, Seoul, Republic of Korea (04563)

Tel : +82 2 3398 8893 / Fax : +82 2 3398 8898

E-mail : enginesales@doosan.com

Website : www.doosaninfracore.com

※Specifications are subject to change without prior notice.

ALTERNATOR DATASHEET



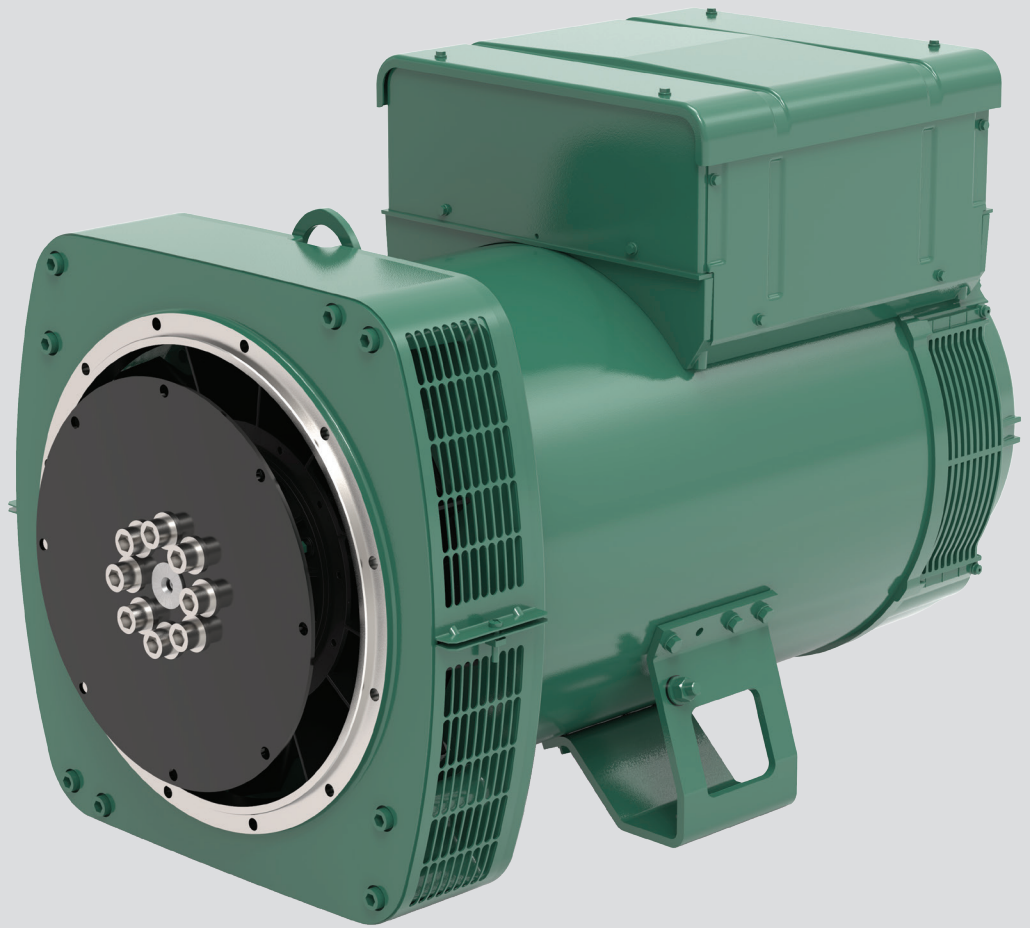

LSA 44.3

Low Voltage Alternator - 4 pole

70 to 200 kVA - 50 Hz / 88 to 250 kVA - 60 Hz
Electrical and mechanical data

LEROY-SOMER[™]

Nidec
All for dreams

The best of performance

Nidec Leroy-Somer LSA 44.3 alternator has been designed to offer you the best power generation performances. With its meticulous design and optimized architecture, the LSA 44.3 strikes the perfect balance between compactness, reliability, performance and longevity.

Whatever your application, the LSA 44.3 will meet your needs and will adapt to all situations.

Standards

Nidec Leroy-Somer LSA 44.3 alternator meets all key international standards and regulations, including IEC 60034, NEMA MG 1.32-33, ISO 8528-3, CSA C22.2 n°100-14 and UL 1446 (UL 1004 on request). Also compliant with IEC 61000-6-2, IEC 61000-6-3, IEC 61000-6-4, VDE 0875G, VDE 0875N and EN 55011, group 1 class A for European zone.

Nidec Leroy-Somer LSA 44.3 alternator can be integrated in EC marked generator set, and bears EC and CMIM markings. It is designed, manufactured and marketed in an ISO 9001 and ISO 14001 quality assurance environment.

Electrical characteristics and performances

- Class H insulation
- 2/3 pitch winding, standard 12-wire (6) reconnectable
- Voltage range:
 - 50 Hz: 220V - 240V and 380V - 415V (440V)
 - 60 Hz: 208V - 240V and 380V - 480V
- High efficiency and motor starting capacity
- Other voltages are possible with optional adapted windings:
 - 50 Hz: 440V (no. 7), 500V (no. 9), 550V (no. 22), 600V (no. 23), 690V (no. 10 or 52)
 - 60 Hz: 380V and 416V (no. 8), 600V (no. 9), 690V (no. 22)

Excitation and regulation system

Excitation system				Regulation options		
AVR	SHUNT	AREP (option)	PMG (option)	C.T. Current transformer for paralleling	Mains paralleling	Remote voltage potentiometer
R250	Standard					√
D350	Option	Standard	Standard	√*		√
D550	Option	Option	Option	√*	√	√

*: only with AREP or PMG

3-phase sensing is included as a standard with digital regulators.

Protection system and options

- The LSA 44.3 is IP 23
- Complete winding protection for clean environments with relative humidity ≤ 95%, including indoor marine environments
- Options:
 - Filters on air inlet: derating 5%
 - Filters on air inlet and air outlet (IP 44): derating 10%
 - Reinforced winding protection for harsh environments and relative humidity greater than 95%
 - Space heater
 - Thermal protection for stator windings
 - Shaft height: H = 225 mm and 280 mm (to be specified when ordering)
 - Cable outlet at right

Mechanical construction

- Compact rigid assembly to better withstand generator vibrations
- Steel frame and terminal box
- Aluminum/cast iron flanges and shields
- Two-bearing and single-bearing versions designed to be suitable for commercially-available heat engines
- Half-key balancing two-bearing
- Greased for life bearings (20 000h)
- Direction of rotation: clockwise and anti-clockwise (without derating)

Terminal box design

- Easy access to the voltage regulator (lid) and to the connections
- Terminal block for reconnecting the voltage

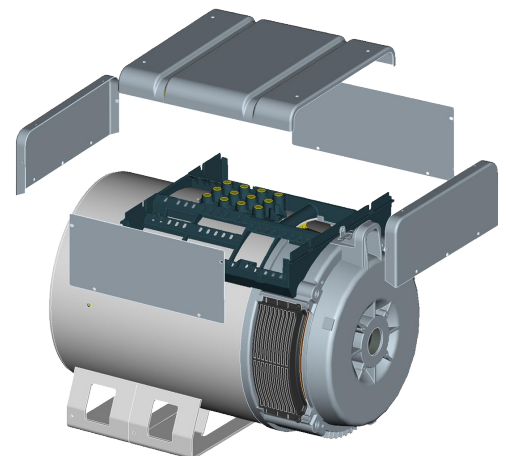

LSA 44.3 - 70 to 200 kVA - 50 Hz / 88 to 250 kVA - 60 Hz

General characteristics

Insulation class	H	Excitation system	SHUNT	AREP / PMG
Winding pitch	2/3 (wind. 6)	AVR type	R250	D350
Number of wires	12	Voltage regulation (*)	± 0.5%	± 0.25%
Protection	IP 23	Short-circuit current	-	300% (3 IN): 10 s
Altitude	≤ 1000 m	Total Harmonic Distortion THD (**) in no-load	< 2%	
Overspeed	2250 R.P.M.	Total Harmonic Distortion THD (**) on linear load ...	< 5%	
Air flow	0.25m³/s (50 Hz) - 0.30m³/s (60 Hz)	Waveform: NEMA = TIF (**)	< 50	
Air flow (***)	0.29m³/s (50 Hz) - 0.34m³/s (60 Hz)	(*) Steady state (**) Total harmonic distortion between phases, no-load or on-load (non-distorting)		

(***) Only for LS 44.3 L12, VL13 & VL14

Ratings 50 Hz - 1500 R.P.M.

Duty/T°C		Continuous duty/40°C					Continuous duty/40°C					Stand-by/40°C					Stand-by/27°C							
Class/T°C		H/125°K					F/105°K					H/150°K					H/163°K							
Phase		3 ph.		1 ph.			3 ph.		1 ph.			3 ph.		1 ph.			3 ph.		1 ph.					
Y		380V	400V	415V	440V	ΔΔ	380V	400V	415V	440V	ΔΔ	380V	400V	415V	440V	ΔΔ	380V	400V	415V	440V	ΔΔ			
Δ		220V	230V	240V	230V		220V	230V	240V	230V		220V	230V	240V	230V		220V	230V	240V	230V				
YY		200V		220V			200V		220V			200V		220V			200V		220V					
LSA 44.3 S2	kVA	70	70	70	63	42	64	64	64	57	38	74	74	74	67	45	77	77	77	69	46			
	kW	56	56	56	50	33.5	51	51	51	46	30.5	59	59	59	54	36	62	62	62	55	37			
LSA 44.3 S3	kVA	80	80	80	72	48	73	73	73	66	44	85	85	85	76	51	88	88	88	79	53			
	kW	64	64	64	58	38.5	58	58	58	53	35	68	68	68	61	41	70	70	70	63	42			
LSA 44.3 S4	kVA	90	90	90	81	54	82	82	82	74	49	95	95	95	86	57	100	100	100	89	59			
	kW	72	72	72	65	43	66	66	66	59	39	76	76	76	69	46	80	80	80	71	47			
LSA 44.3 S5	kVA	100	100	100	90	60	91	91	91	82	55	106	106	106	95	64	110	110	110	99	66			
	kW	80	80	80	72	48	73	73	73	66	44	85	85	85	76	51	88	88	88	79	53			
LSA 44.3 M6	kVA	125	125	125	113	67	114	114	114	103	61	133	133	133	120	71	138	138	138	124	74			
	kW	100	100	100	90	54	91	91	91	82	49	106	106	106	96	57	110	110	110	99	59			
LSA 44.3 M8	kVA	135	135	135	122	73	123	123	123	111	66	143	143	143	129	77	150	150	150	134	80			
	kW	108	108	108	98	58	98	98	98	89	53	114	114	114	103	62	120	120	120	107	64			
LSA 44.3 L10	kVA	150	150	150	135	80	137	137	137	123	73	159	159	159	143	85	165	165	165	149	88			
	kW	120	120	120	108	64	110	110	110	98	58	127	127	127	114	68	132	132	132	119	70			
LSA 44.3 L12	kVA	165	165	165	138	88	150	150	150	126	80	175	175	175	150	93	182	182	182	157	97			
	kW	132	132	132	110	70	120	120	120	101	64	140	140	140	120	74	146	146	146	126	78			
LSA 44.3 VL13	kVA	180	180	180	171	90	164	164	164	156	82	191	191	191	181	95	200	200	200	188	99			
	kW	144	144	144	137	72	131	131	131	125	66	153	153	153	145	76	160	160	160	150	79			
LSA 44.3 VL14	kVA	192	200	200	192	100	175	182	182	175	91	204	212	212	204	106	211	220	220	211	110			
	kW	154	160	160	154	80	140	146	146	140	73	163	170	170	163	85	169	176	176	169	88			

Ratings 60 Hz - 1800 R.P.M.

Duty/T°C		Continuous duty/40°C					Continuous duty/40°C					Stand-by/40°C					Stand-by/27°C							
Class/T°C		H/125°K					F/105°K					H/150°K					H/163°K							
Phase		3 ph.		1 ph.			3 ph.		1 ph.			3 ph.		1 ph.			3 ph.		1 ph.					
Y		380V	416V	440V	480V	ΔΔ	380V	416V	440V	480V	ΔΔ	380V	416V	440V	480V	ΔΔ	380V	416V	440V	480V	ΔΔ			
Δ		220V	240V	240V	240V		220V	240V	240V	240V		220V	240V	240V	240V		220V	240V	240V	240V				
YY		208V		240V			208V		240V			208V		240V			208V		240V					
LSA 44.3 S2	kVA	69	76	80	88	46	63	69	73	80	42	73	81	85	93	49	76	84	88	97	51			
	kW	55	61	64	70	37	50	55	58	64	33.5	58	65	68	74	39	61	67	70	78	41			
LSA 44.3 S3	kVA	79	87	92	100	52	72	79	84	91	47	84	92	98	106	55	87	96	101	110	57			
	kW	63	70	74	80	42	58	63	67	73	37.5	67	74	78	85	44	70	77	81	88	46			
LSA 44.3 S4	kVA	89	98	103	113	59	81	89	94	103	54	94	104	109	120	63	98	108	113	124	65			
	kW	71	78	82	90	47	65	71	75	82	43	75	83	87	96	50	78	86	90	99	52			
LSA 44.3 S5	kVA	99	108	115	125	65	90	99	105	114	59	105	114	122	133	69	109	119	127	138	72			
	kW	79	86	92	100	52	72	79	84	91	47	84	91	98	106	55	87	95	102	110	58			
LSA 44.3 M6	kVA	124	135	143	156	76	113	123	130	142	69	131	143	152	165	81	136	149	157	172	84			
	kW	99	108	114	125	61	90	98	104	114	55	105	114	122	132	65	109	119	126	138	67			
LSA 44.3 M8	kVA	134	146	155	169	81	122	133	141	154	74	142	155	164	179	86	147	161	171	186	89			
	kW	107	117	124	135	65	98	106	113	123	59	114	124	131	143	69	118	129	137	149	71			
LSA 44.3 L10	kVA	148	163	172	188	95	135	148	157	171	86	157	173	182	199	101	163	179	189	207	105			
	kW	118	130	138	150	76	108	118	126	137	69	126	138	146	159	81	130	143	151	166	84			
LSA 44.3 L12	kVA	165	179	189	206	105	150	163	172	187	96	175	190	200	218	111	182	197	208	227	116			
	kW	132	143	151	165	84	120	130	138	150	77	140	152	160	174	89	146	158	166	182	93			
LSA 44.3 VL13	kVA	180	195	210	225	113	164	177	191	205	102	191	207	223	239	119	200	215	231	250	124			
	kW	144	156	168	180	90	131	142	153	164	82	153	166	178	191	95	160	172	185	200	99			
LSA 44.3 VL14	kVA	200	215	230	250	125	182	196	209	228	114	212	228	244	265	133	220	237	253	275	136			
	kW	160	172	184	200	100	146	157	167	182	91	170	182	195	212	106	176	190	202	220	109			

* Values are rounded-off and are subject to change without notice by the manufacturer.

LSA 44.3 - 70 to 200 kVA - 50 Hz / 88 to 250 kVA - 60 Hz

Efficiencies 400 V - 50 Hz (— P.F.: 0.8) (--- P.F.: 1)

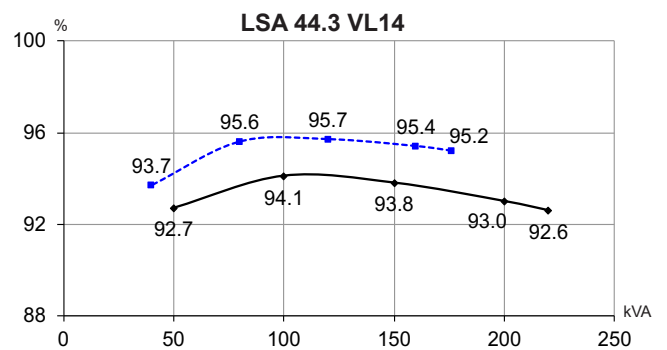
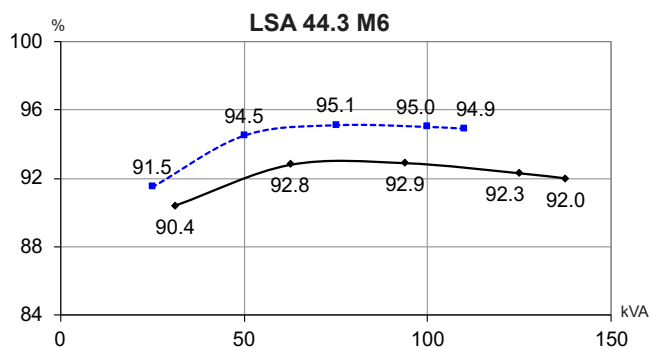
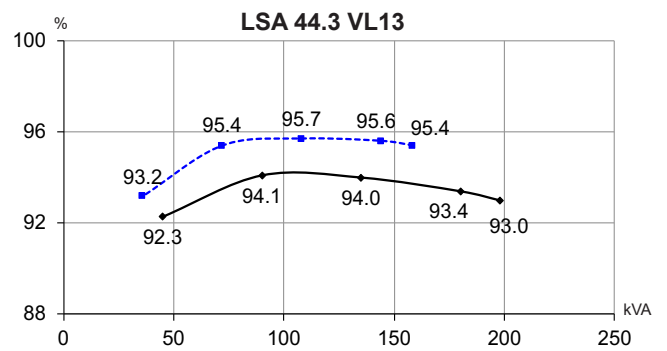
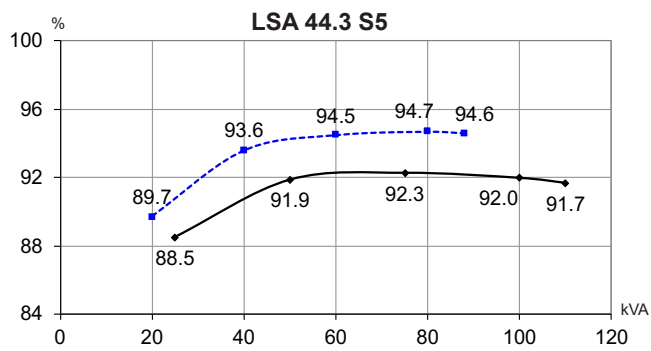
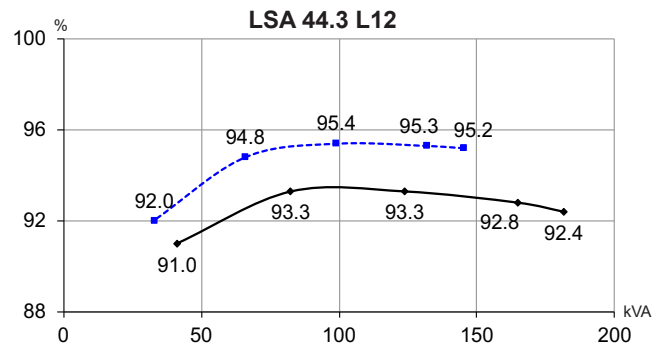
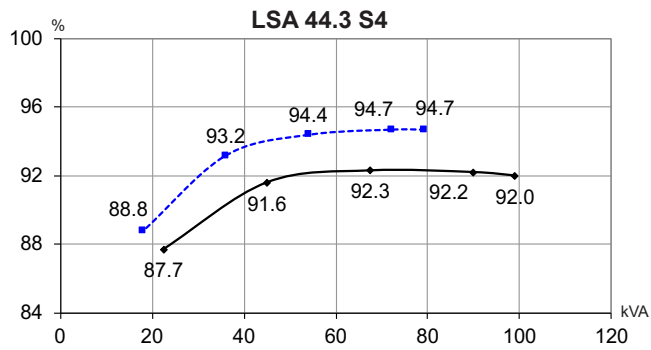
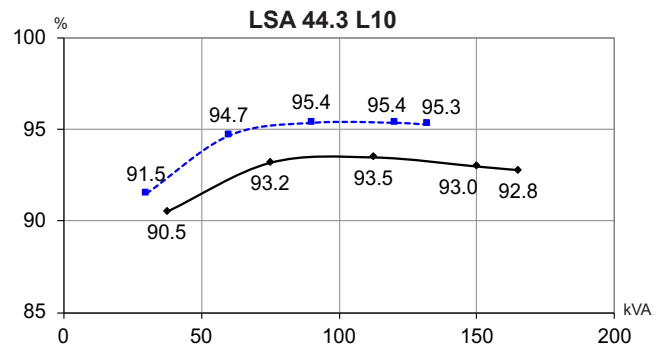
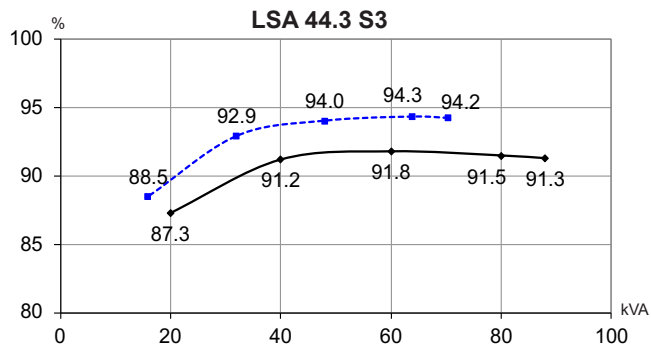
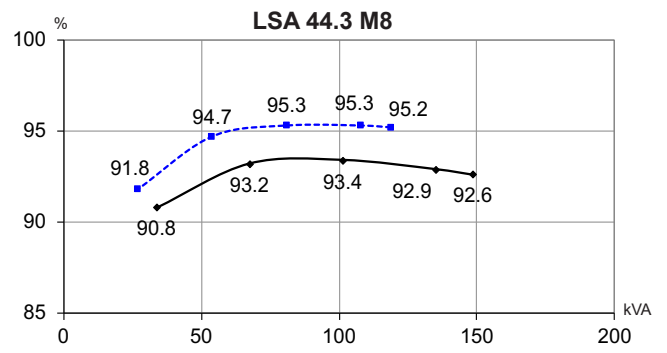
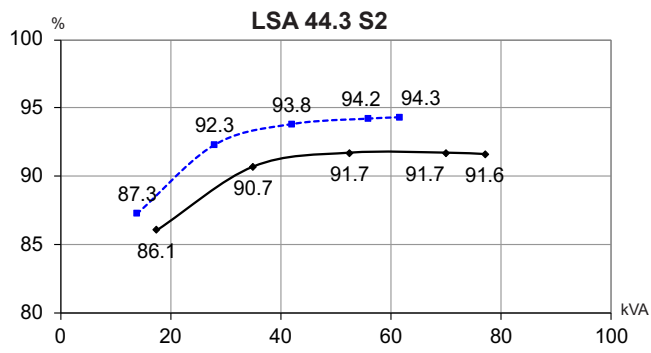

LSA 44.3 - 70 to 200 kVA - 50 Hz / 88 to 250 kVA - 60 Hz

Efficiencies 480 V - 60 Hz (— P.F.: 0.8) (- - - P.F.: 1)

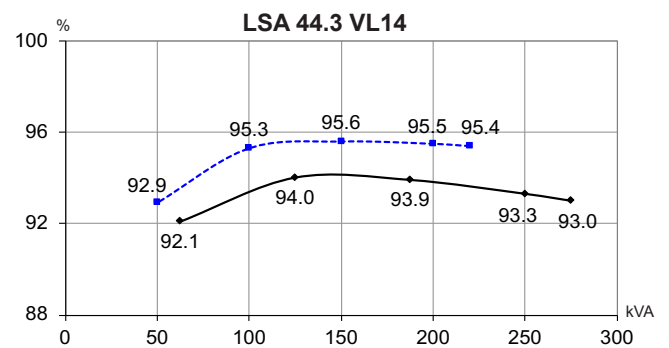
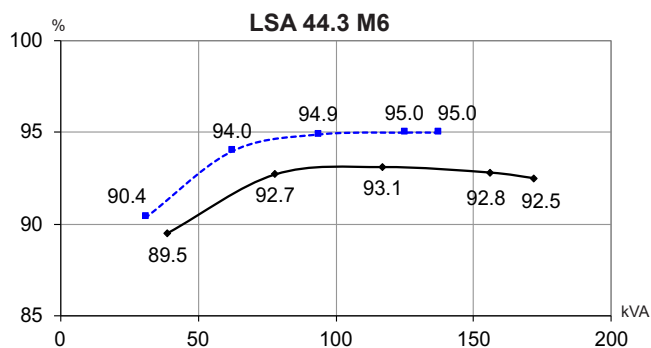
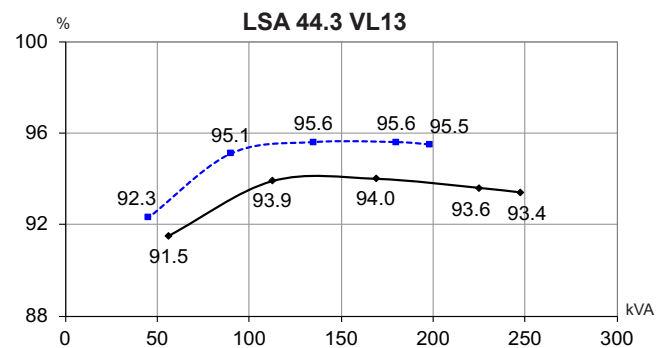
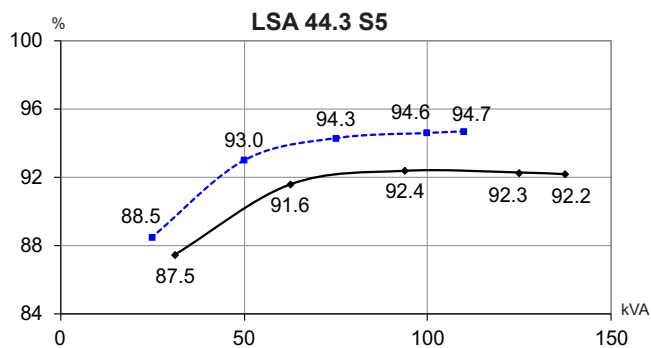
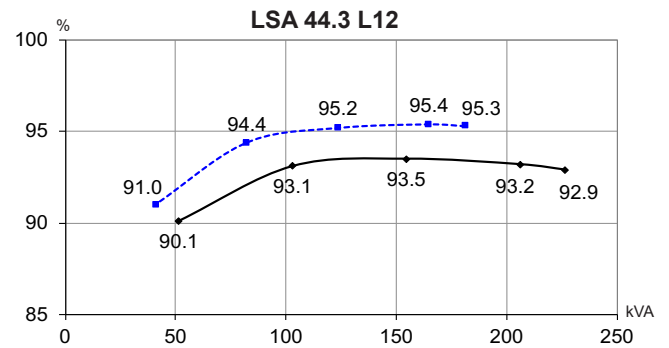
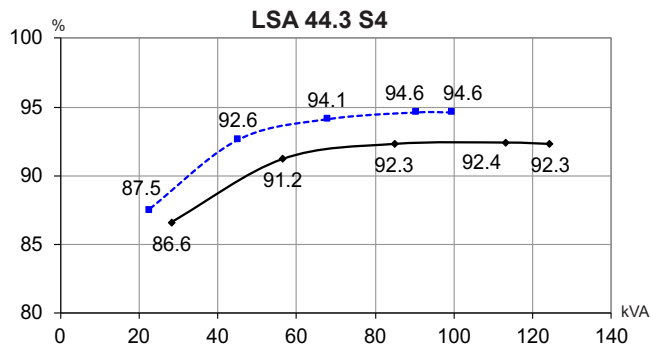
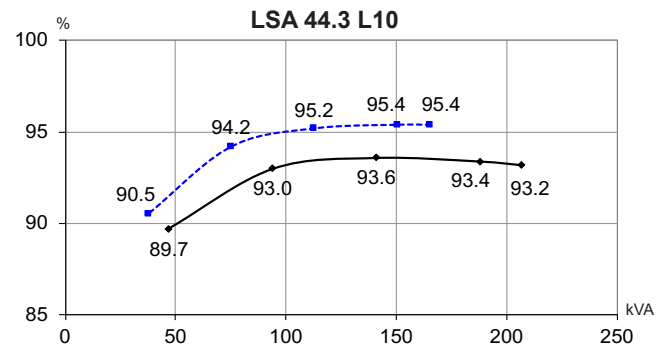
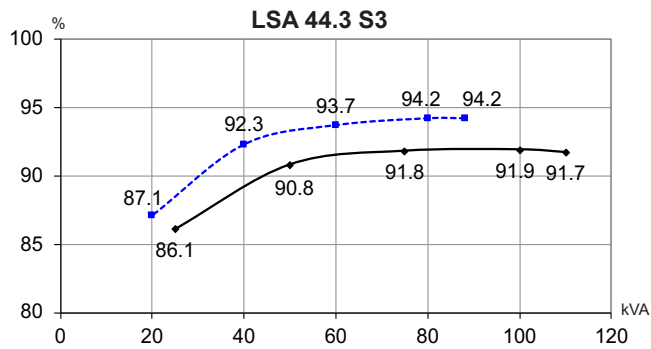
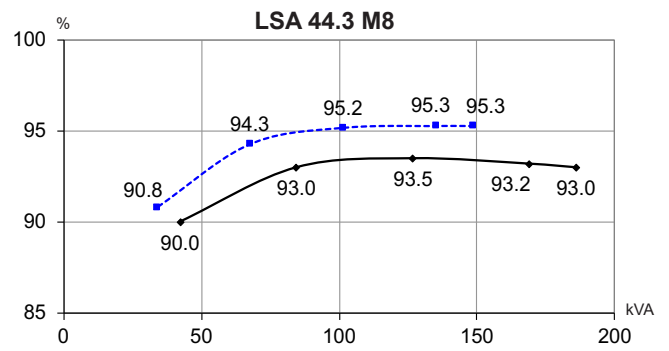
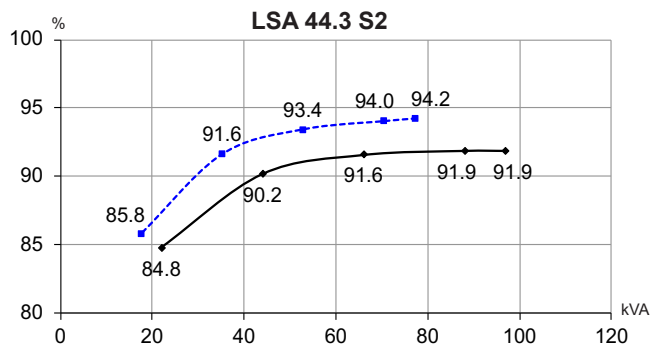

Reactances (%). Time constants (ms) - Class H / 400 V

	S2	S3	S4	S5	M6	M8	L10	L12	VL13	VL14
Kcc Short-circuit ratio	0.68	0.59	0.61	0.55	0.45	0.44	0.49	0.44	0.37	0.33
Xd Direct-axis synchronous reactance unsaturated	239	273	258	287	329	323	305	335	343	381
Xq Quadrature-axis synchronous reactance unsaturated	121	139	131	146	167	165	155	171	175	194
T'do No-load transient time constant	2308	2308	2211	2211	2154	2112	2077	2077	2025	2025
X'd Direct-axis transient reactance saturated	10.3	11.8	11.6	12.9	15.2	15.3	14.6	16.1	16.9	18.8
T'd Short-circuit transient time constant	100	100	100	100	100	100	100	100	100	100
X''d Direct-axis subtransient reactance saturated	6.2	7	7	7.7	9.1	9.1	8.8	9.6	10.1	11.3
T''d Subtransient time constant	10	10	10	10	10	10	10	10	10	10
X''q Quadrature-axis subtransient reactance saturated	13.2	15.1	14.5	16.1	18.6	18.3	17.4	19.1	19.7	21.9
Xo Zero sequence reactance	0.43	0.49	0.48	0.54	0.63	0.63	0.61	0.67	0.7	0.78
X2 Negative sequence reactance saturated	9.74	11.13	10.75	11.95	13.89	13.78	13.11	14.42	14.96	16.62
Ta Armature time constant	15	15	15	15	15	15	15	15	15	15

Other class H / 400 V data

io (A) No-load excitation current SHUNT	0.75	0.75	0.73	0.73	0.66	0.62	0.67	0.67	0.78	0.78
io (A) No-load excitation current AREP	0.97	0.97	0.94	0.94	0.85	0.81	0.86	0.86	0.78	0.78
ic (A) On-load excitation current SHUNT	2.07	2.33	2.11	2.31	2.47	2.37	2.45	2.71	3.17	3.53
ic (A) On-load excitation current AREP	2.67	3	2.71	2.98	3.18	3.05	3.15	3.49	3.17	3.53
uc (V) On-load excitation voltage SHUNT	23.1	25.8	26.5	28.9	30.6	29.3	29.9	32.7	16.2	17.9
uc (V) On-load excitation voltage AREP	18.6	20.7	21.3	23.2	24.5	23.5	24	26.3	16.2	17.9
ms Response time ($\Delta U = 20\%$ transient)	500	500	500	500	500	500	500	500	500	500
kVA Start ($\Delta U = 20\%$ cont. or $\Delta U = 30\%$ trans.) SHUNT*	184	184	292	293	310	334	371	379	487	487
kVA Start ($\Delta U = 20\%$ cont. or $\Delta U = 30\%$ trans.) AREP*	222	221	344	344	366	400	414	414	545	545
% Transient ΔU (on-load 4/4) SHUNT - P.F.: 0.8 _{LAG}	13.3	14.5	11.6	12.4	13.8	13.8	13.4	14.3	13	13.9
% Transient ΔU (on-load 4/4) AREP - P.F.: 0.8 _{LAG}	11.8	12.9	10.4	11.1	12.3	12.3	12	12.7	11.6	12.4
W No-load losses	2174	2174	2396	2396	2387	2478	2894	2946	2670	2670
W Heat dissipation	5025	5892	6073	6935	8254	8251	8914	10236	10165	11933

* P.F. = 0.6

Reactances (%). Time constants (ms) - Class H / 480 V

	S2	S3	S4	S5	M6	M8	L10	L12	VL13	VL14
Kcc Short-circuit ratio	0.65	0.57	0.58	0.53	0.43	0.42	0.47	0.43	0.36	0.32
Xd Direct-axis synchronous reactance unsaturated	250	284	270	299	342	337	318	349	358	397
Xq Quadrature-axis synchronous reactance unsaturated	127	145	137	152	174	172	162	178	182	202
T'do No-load transient time constant	2308	2308	2211	2211	2154	2112	2077	2077	2025	2025
X'd Direct-axis transient reactance saturated	10.8	12.3	12.2	13.5	15.8	15.9	15.3	16.8	17.6	19.6
T'd Short-circuit transient time constant	100	100	100	100	100	100	100	100	100	100
X''d Direct-axis subtransient reactance saturated	6.5	7.3	7.3	8.1	9.5	9.5	9.2	10	10.6	11.7
T''d Subtransient time constant	10	10	10	10	10	10	10	10	10	10
X''q Quadrature-axis subtransient reactance saturated	13.9	15.7	15.1	16.7	19.3	19.1	18.1	19.9	20.5	22.8
Xo Zero sequence reactance	0.45	0.51	0.5	0.56	0.66	0.66	0.63	0.7	0.73	0.81
X2 Negative sequence reactance saturated	10.2	11.59	11.25	12.44	14.44	14.37	13.7	15	15.59	17.32
Ta Armature time constant	15	15	15	15	15	15	15	15	15	15

Other class H / 480 V data

io (A) No-load excitation current SHUNT	0.75	0.75	0.73	0.73	0.66	0.62	0.67	0.67	0.77	0.77
io (A) No-load excitation current AREP	0.97	0.97	0.94	0.94	0.85	0.81	0.86	0.86	0.77	0.77
ic (A) On-load excitation current SHUNT	2.08	2.31	2.13	2.32	2.47	2.38	2.44	2.68	3.21	3.56
ic (A) On-load excitation current AREP	2.67	2.98	2.75	2.99	3.18	3.06	3.14	3.45	3.21	3.56
uc (V) On-load excitation voltage SHUNT	23.5	26	27	29.4	31	29.7	30.3	33	16.6	18.3
uc (V) On-load excitation voltage AREP	18.8	20.8	21.7	23.6	24.9	23.9	24.3	26.5	16.6	18.3
ms Response time ($\Delta U = 20\%$ transient)	500	500	500	500	500	500	500	500	500	500
kVA Start ($\Delta U = 20\%$ cont. or $\Delta U = 30\%$ trans.) SHUNT*	220	222	352	351	374	403	465	466	589	587
kVA Start ($\Delta U = 20\%$ cont. or $\Delta U = 30\%$ trans.) AREP*	265	265	422	423	446	481	541	544	708	706
% Transient ΔU (on-load 4/4) SHUNT - P.F.: 0.8 _{LAG}	13.7	14.9	12	12.7	14.1	14.2	13.8	14.7	13.3	14.3
% Transient ΔU (on-load 4/4) AREP - P.F.: 0.8 _{LAG}	12.2	13.2	10.7	11.4	12.6	12.6	12.3	13	11.9	12.7
W No-load losses	3188	3188	3501	3501	3506	3639	4217	4308	3928	3928
W Heat dissipation	6152	7047	7349	8241	9669	9747	10581	11988	12155	14140

* P.F. = 0.6

Transient voltage variation 400V - 50 Hz

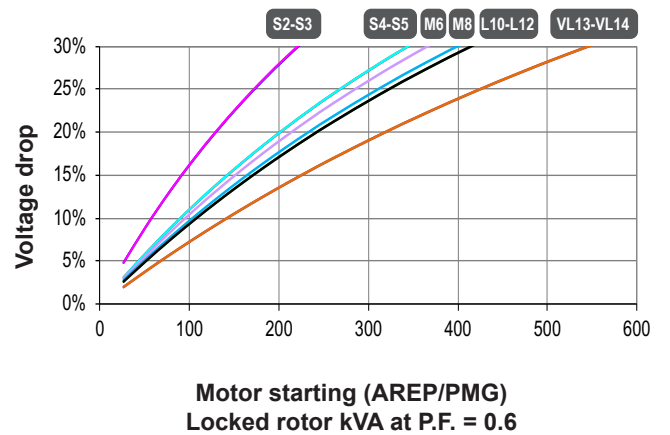
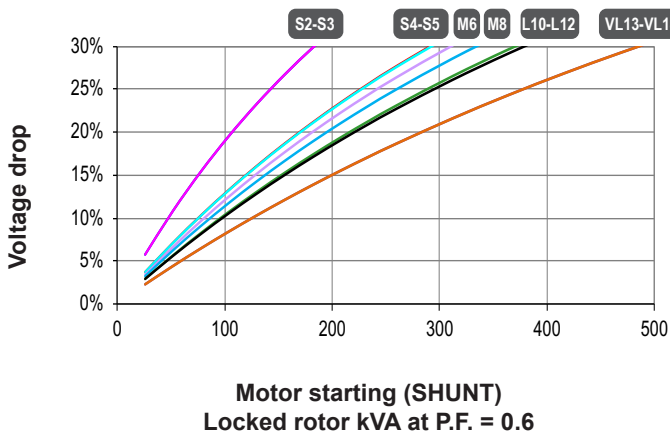
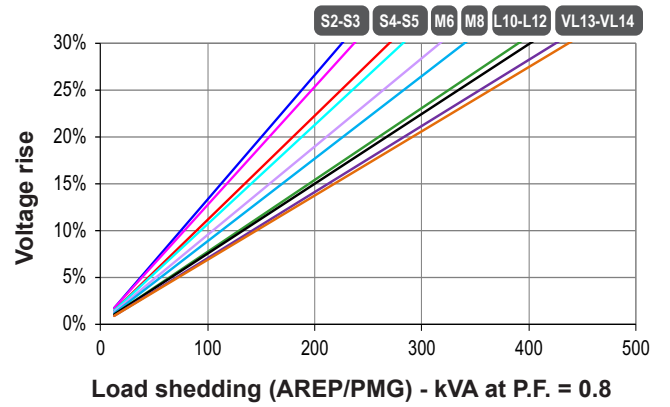
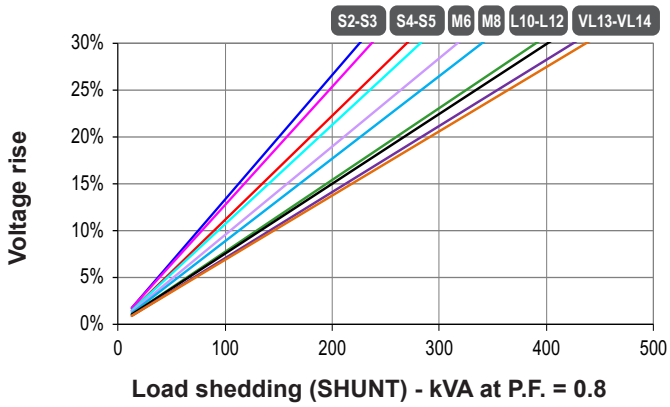
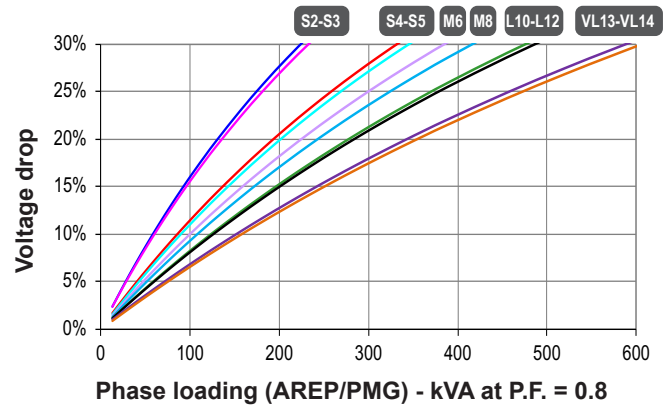
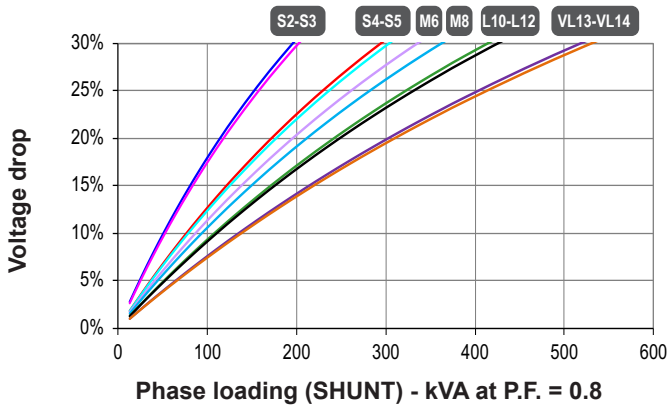

1) For a starting P.F. other than 0.6, the starting kVA must be multiplied by $K = \text{Sine P.F.} / 0.8$
 2) For voltages other than 400V (Y), 230V (Δ) at 50 Hz, then kVA must be multiplied by $(400/U)^2$ or $(230/U)^2$.

Transient voltage variation 480V - 60 Hz

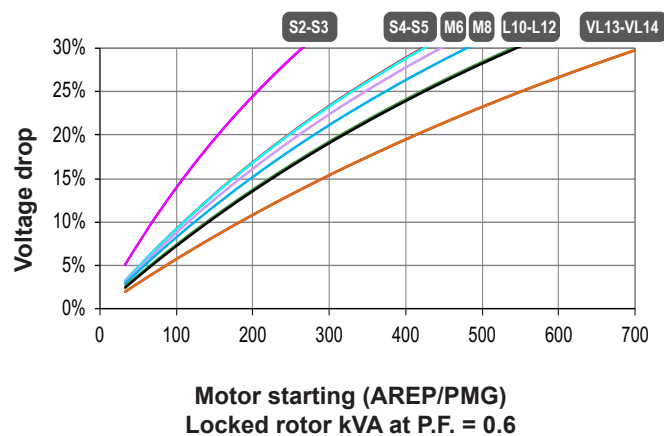
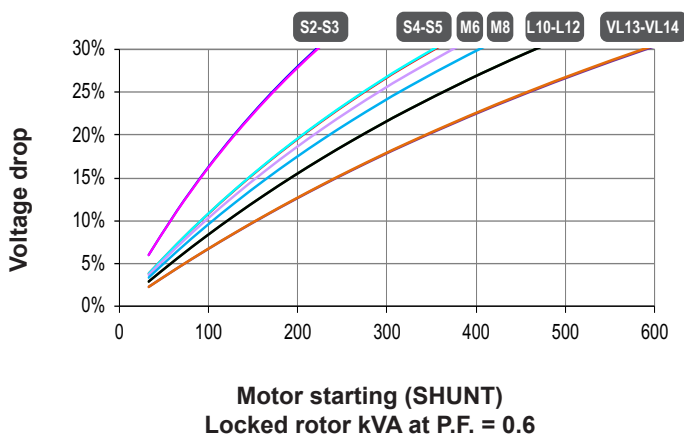
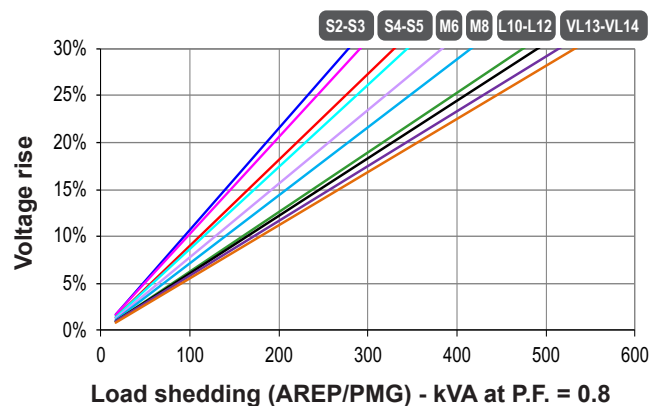
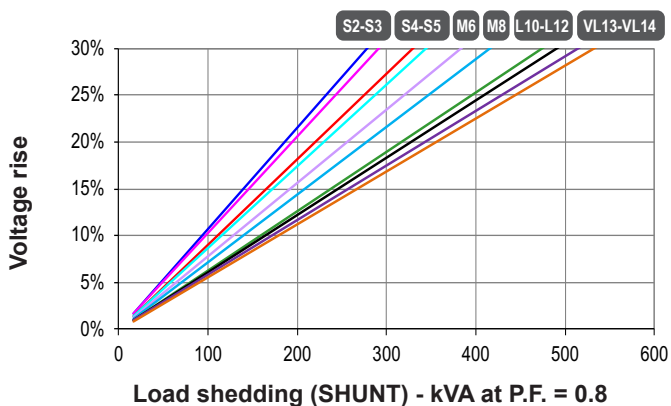
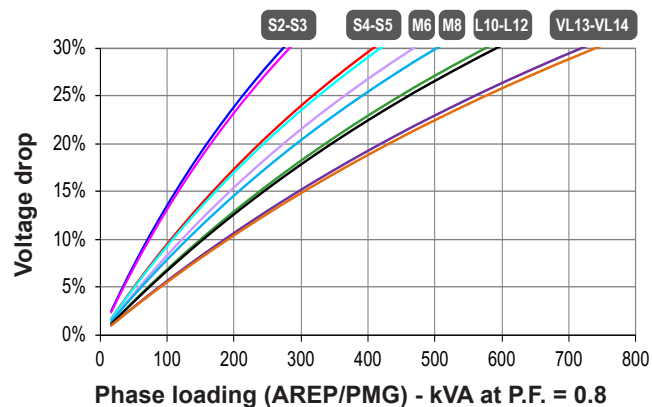
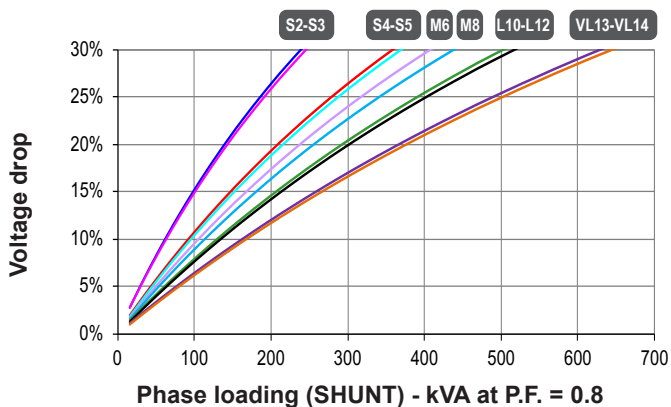

- 1) For a starting P.F. other than 0.6, the starting kVA must be multiplied by $K = \text{Sine P.F.} / 0.6$
- 2) For voltages other than 480V (Y), 277V (Δ), 240V (YY) at 60 Hz, then kVA must be multiplied by $(480/U)^2$ or $(277/U)^2$ or $(240/U)^2$.

3-phase short-circuit curves at no load and rated speed (star connection Y)

LSA 44.3 S2

Symmetrical —
Asymmetrical - - -

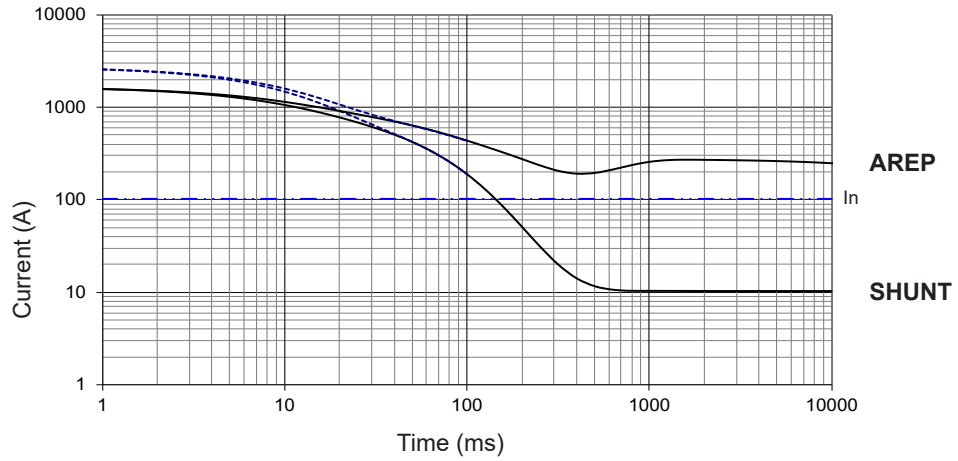

LSA 44.3 S3

Symmetrical —
Asymmetrical - - -

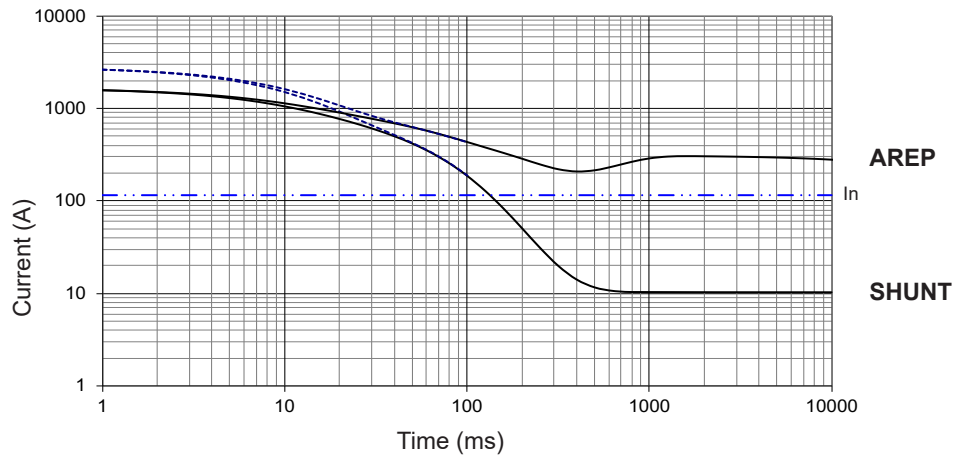

LSA 44.3 S4

Symmetrical —
Asymmetrical - - -

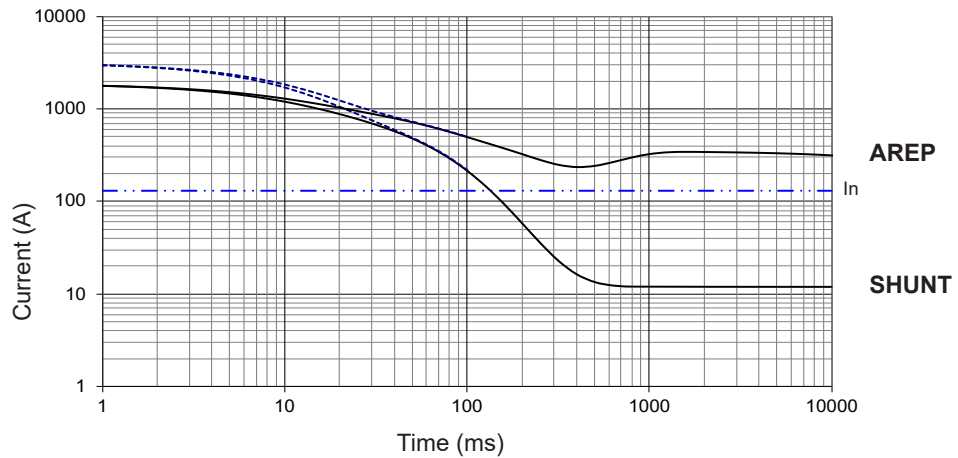

Influence due to connection

Curves shown are for star (Y) connection.

For other connections, use the following multiplication factors:

- Series delta : current value x 1.732 - Parallel star : current value x 2

3-phase short-circuit curves at no load and rated speed (star connection Y)

LSA 44.3 S5

Symmetrical —
Asymmetrical - - -

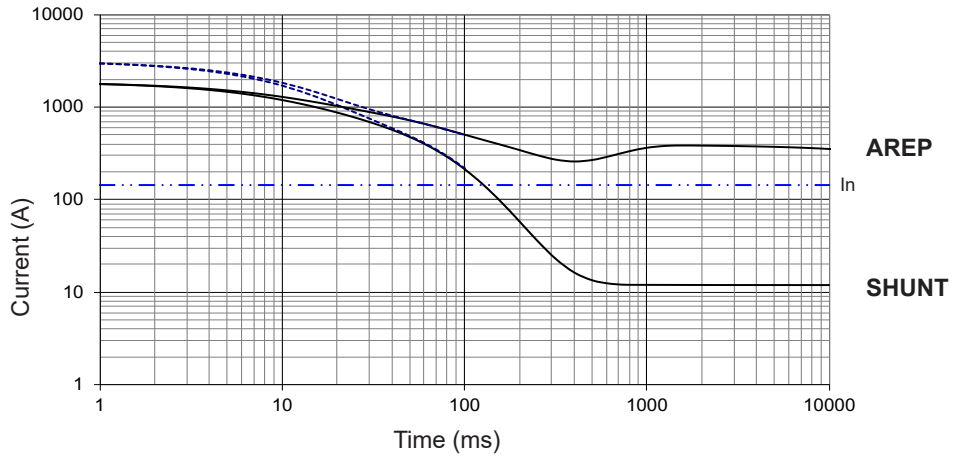

LSA 44.3 M6

Symmetrical —
Asymmetrical - - -

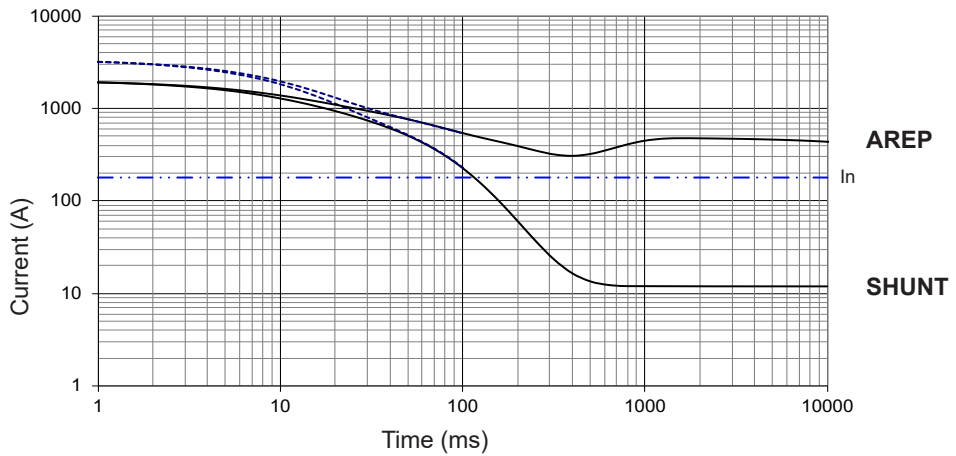

LSA 44.3 M8

Symmetrical —
Asymmetrical - - -

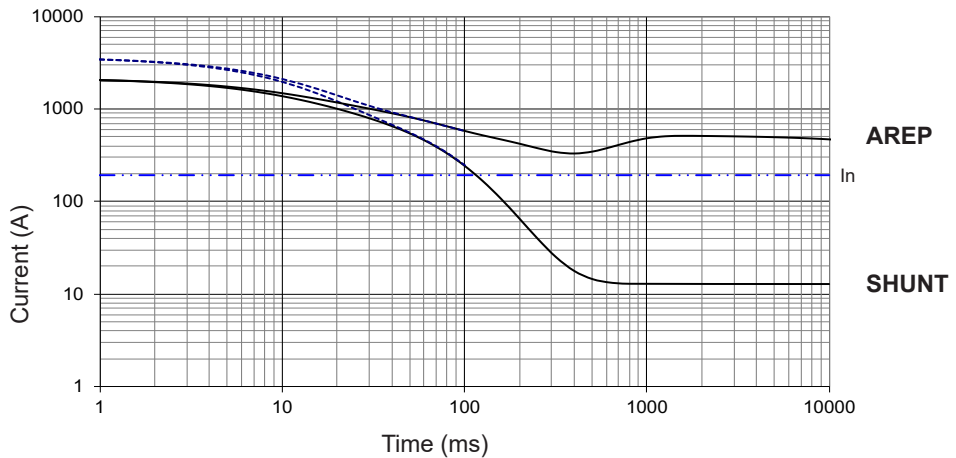

Influence due to short-circuit

Curves are based on a three-phase short-circuit.

For other types of short-circuit, use the following multiplication factors.

	3-phase	2-phase L/L	1-phase L/N
Instantaneous (max.)	1	0.87	1.3
Continuous	1	1.5	2.2
Maximum duration (AREP/PMG)	10 sec.	5 sec.	2 sec.

3-phase short-circuit curves at no load and rated speed (star connection Y)

LSA 44.3 L10

Symmetrical —
Asymmetrical - - -

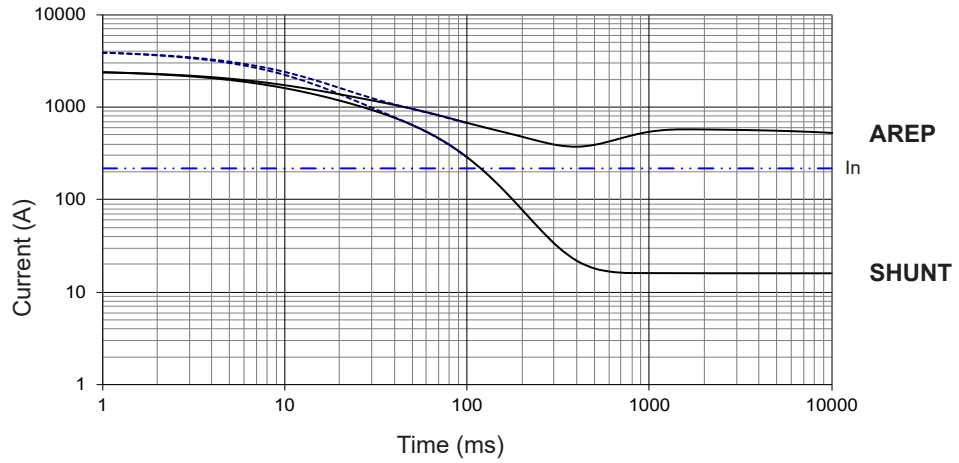

LSA 44.3 L12

Symmetrical —
Asymmetrical - - -

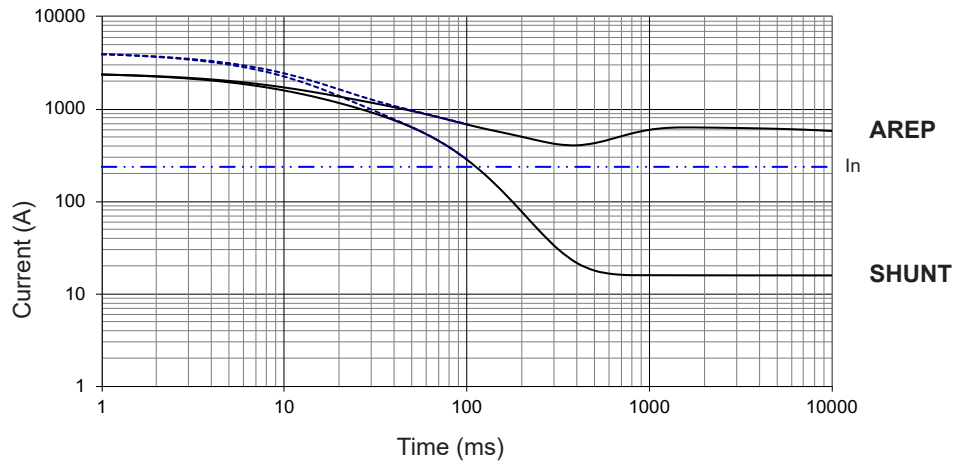

Influence due to connection

Curves shown are for star (Y) connection.

For other connections, use the following multiplication factors:

- Series delta : current value x 1.732
- Parallel star : current value x 2

3-phase short-circuit curves at no load and rated speed (star connection Y)

LSA 44.3 VL13

Symmetrical —
Asymmetrical - - -

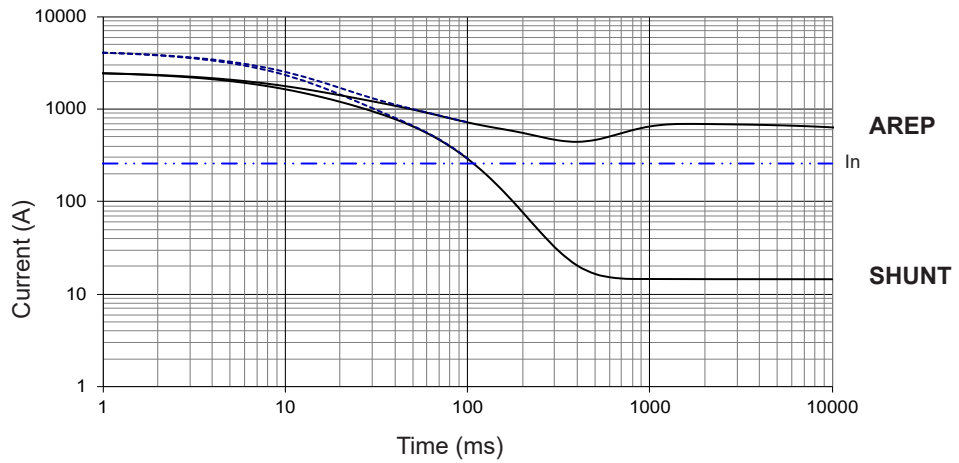

LSA 44.3 VL14

Symmetrical —
Asymmetrical - - -

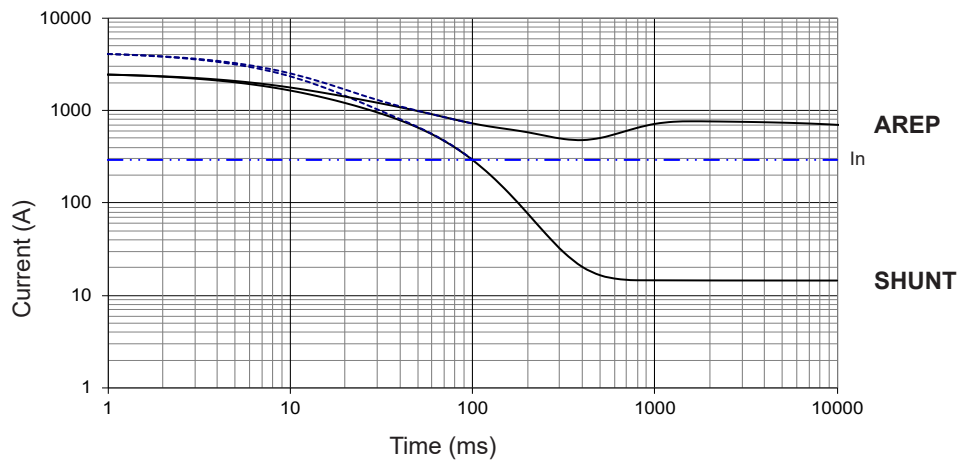

Influence due to short-circuit

Curves are based on a three-phase short-circuit.

For other types of short-circuit, use the following multiplication factors.

	3-phase	2-phase L/L	1-phase L/N
Instantaneous (max.)	1	0.87	1.3
Continuous	1	1.5	2.2
Maximum duration (AREP/PMG)	10 sec.	5 sec.	2 sec.

Single-bearing dimensions

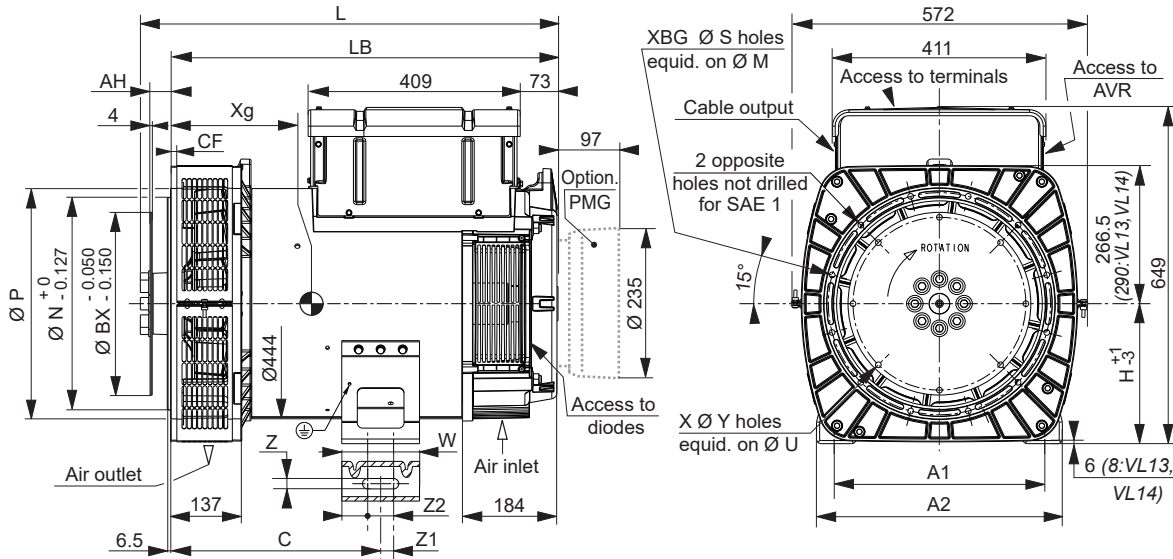

Dimensions (mm) and weight				
Type	L without PMG maxi*	LB	Xg	Weight (kg)
LSA 44.3 S2	758	677	313	295
LSA 44.3 S3	758	677	313	295
LSA 44.3 S4	758	677	329	332
LSA 44.3 S5	758	677	329	332
LSA 44.3 M6	828	747	353	368
LSA 44.3 M8	828	747	365	398
LSA 44.3 L10	868	787	383	433
LSA 44.3 L12	868	787	383	433
LSA 44.3 VL13	953	872	416	554
LSA 44.3 VL14	953	872	416	554

* L maxi = LB + AH maxi + 19

Flange (mm)						
S.A.E.	P	N	M	S	XBG	CF
4	400	361.95	381	11	12	16
3	445	409.58	428.62	11	12	16
2	485	447.68	466.72	11	12	16
1	560.5/581*	511.18	530.23	12	10	4.5/10*

* Specific dimension LSA 44.3 VL13 and VL14

Shaft height (mm)			
	Standard	Option	
H	270	225*	280**
Feet length			
C	405	332.5	429
A1	406	356	457
A2	474	430	541
Z	20	14.5	20
Z1	25	20	25
Z2	50	40	50
W	150	120	150

* Not available for VL13 and VL14
** Available only for VL13 and VL14

Flex plate (mm)					
S.A.E.	BX	U	X	Y	AH
14	466.72	438.15	8	14	25.4
11 1/2	352.42	333.38	8	11	39.6
10	314.32	295.28	8	11	53.8
8	263.52	244.48	6	11	62

Coupling				
Flange	1	2	3	4
14	x	-	-	-
11 1/2	x	x	x	-
10	x	x	x	x
8	-	-	x	x

Torsional analysis data

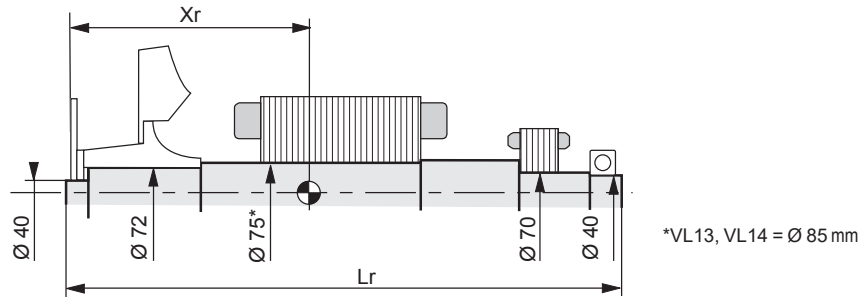

*VL13, VL14 = Ø 85 mm

Centre of gravity: Xr (mm), Rotor length: Lr (mm), Weight: M (kg), Moment of inertia: J (kgm²): (4J = MD²)																
Flex plate	S.A.E. 8				S.A.E. 10				S.A.E. 11 1/2				S.A.E. 14			
	Xr	Lr	M	J	Xr	Lr	M	J	Xr	Lr	M	J	Xr	Lr	M	J
LSA 44.3 S2	362	729	121	0.855	353	729	121	0.868	322	729	127	0.883	318	729	123	1.007
LSA 44.3 S3	362	729	121	0.855	353	729	121	0.868	322	729	127	0.883	318	729	123	1.007
LSA 44.3 S4	383	729	139	1.013	372	729	139	1.026	359	729	138	1.041	337	729	141	1.165
LSA 44.3 S5	383	729	139	1.013	372	729	139	1.026	359	729	138	1.041	337	729	141	1.165
LSA 44.3 M6	408	799	154	1.129	399	799	154	1.142	386	799	153	1.157	364	799	156	1.281
LSA 44.3 M8	418	799	165	1.236	410	799	165	1.249	397	799	165	1.264	373	799	168	1.388
LSA 44.3 L10	438	839	181	1.371	429	839	181	1.384	417	839	180	1.399	397	839	183	1.523
LSA 44.3 L12	437	839	181	1.381	428	839	181	1.394	416	839	181	1.409	396	839	184	1.533
LSA 44.3 VL13	473	922.4	224	1.739	465	914	224	1.753	451	899	224	1.769	436.5	906	231	1.899
LSA 44.3 VL14	473	922.4	224	1.739	465	914	224	1.753	451	899	224	1.769	436.5	906	231	1.899

NOTE : Dimensions are for information only and may be subject to modifications. Contractual 2D drawings can be downloaded from the Leroy-Somer site, 3D drawing files are available upon request. The torsional analysis of the transmission is imperative. All values are available upon request.

Two-bearing dimensions

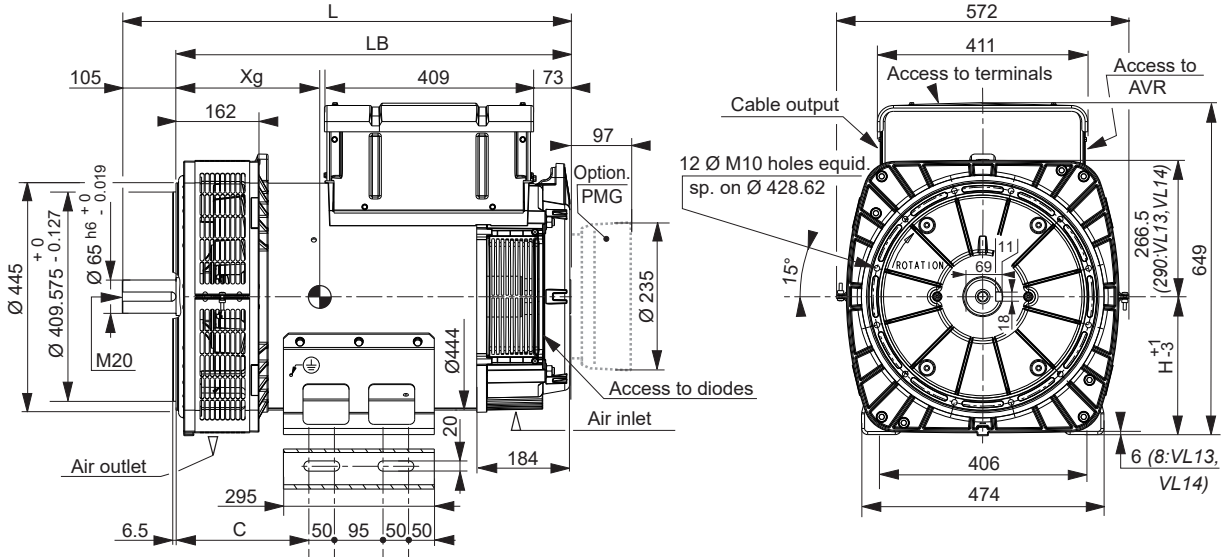

Dimensions (mm) and weight

Type	L without PMG	LB	Xg	C	H*	Weight (kg)
LSA 44.3 S2	807	702	333	260	270	301
LSA 44.3 S3	807	702	333	260	270	301
LSA 44.3 S4	807	702	350	260	270	338
LSA 44.3 S5	807	702	350	260	270	338
LSA 44.3 M6	877	772	373	260	270	374
LSA 44.3 M8	877	772	385	260	270	404
LSA 44.3 L10	917	812	403	260	270	439
LSA 44.3 L12	917	812	393	260	270	439
LSA 44.3 VL13	1002	897	422	285	270	555
LSA 44.3 VL14	1002	897	422	285	270	555

* H options: 225 mm, not available for VL13 and VL14, or 280 mm, available only for VL13 and VL14. Drawing available upon request.

Torsional analysis data

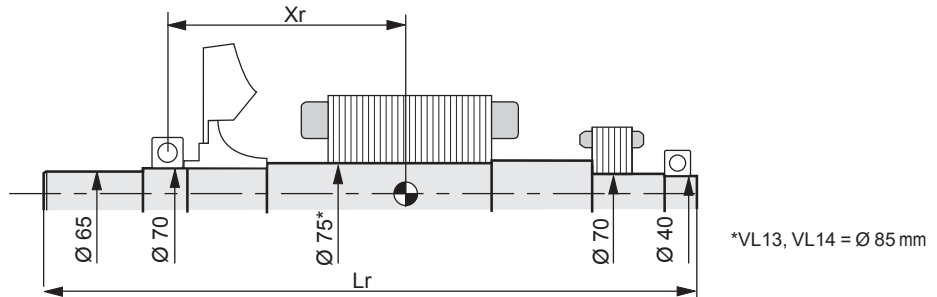

Centre of gravity: Xr (mm), Rotor length: Lr (mm), Weight: M (kg), Moment of inertia: J (kgm²): (4J = MD²)

Type	Xr	Lr	M	J
LSA 44.3 S2	309	793	117	0.825
LSA 44.3 S3	309	793	117	0.825
LSA 44.3 S4	329	793	135	0.988
LSA 44.3 S5	329	793	135	0.988
LSA 44.3 M6	353	863	149	1.096
LSA 44.3 M8	363	863	161	1.203
LSA 44.3 L10	383	903	176	1.346
LSA 44.3 L12	382	903	177	1.356
LSA 44.3 VL13	409	988	219.5	1.706
LSA 44.3 VL14	409	988	219.5	1.706

NOTE : Dimensions are for information only and may be subject to modifications. Contractual 2D drawings can be downloaded from the Leroy-Somer site, 3D drawing files are available upon request. The torsional analysis of the transmission is imperative. All values are available upon request.

LEROY-SOMER[™]

www.leroy-somer.com/epg

Connect with us at:



Nidec
All for dreams

© 2022 Moteurs Leroy-Somer SAS. The information contained in this brochure is for guidance only and does not form part of any contract. The accuracy cannot be guaranteed as Moteurs Leroy-Somer SAS have an ongoing process of development and reserve the right to change the specification of their products without notice.

Moteurs Leroy-Somer SAS. Headquarters: Bd Marcellin Leroy, CS 10015, 16915 Angoulême Cedex 9, France. Share Capital: 38,679,664 €, RCS Angoulême 338 567 258.

CONTROLLER DATASHEET



DSE7310/20 MKII

AUTO START & AUTO MAINS FAILURE CONTROL MODULES



KEY FEATURES

- Configurable power-up mode
- MPU fail delay
- Enhanced graphical user interface
- Drag & drop advanced PLC editor
- MSC ID within PLC GenComm override
- 4-Line back-lit LCD text display
- Multiple Display Languages
- Five key menu navigation
- LCD alarm indication
- Heated display option available
- Customisable power-up text and images
- DSENet expansion compatibility
- Data logging facility
- Internal PLC editor
- Protections disable feature
- Fully configurable via PC using USB, RS232 & RS485 communication
- Front panel configuration with PIN protection
- Power save mode
- 3 phase generator sensing and protection
- 3 phase mains (utility) sensing and protection (DSE7320 MKII only)
- Automatic load transfer control (DSE7320 MKII only)
- Generator current and power monitoring (kW, kvar, kVA, pf)
- Mains current and power monitoring (kW, kvar, kVA, pf) (DSE7320 MKII only)
- kW and kvar overload and reverse power alarms
- Over current protection
- Unbalanced load protection
- Independent earth fault protection
- Breaker control via fascia buttons
- Fuel and start outputs configurable when using CAN
- 6 configurable DC outputs
- 2 configurable volt-free relay outputs
- 6 configurable analogue/digital inputs
- Support for 0 V to 10 V & 4 mA to 20 mA sensors
- 8 configurable digital inputs
- Configurable 5 stage dummy load and load shedding outputs
- CAN, MPU and alternator frequency speed sensing in one variant
- Real time clock
- Manual and automatic fuel pump control
- Engine pre-heat and post-heat functions
- Engine run-time scheduler
- Engine idle control for starting & stopping
- Fuel usage monitor and low fuel level alarms
- Simultaneous use of RS232 and RS485 communication ports
- True dual mutual standby using RS232 or RS485 for accurate engine hours balancing.
- MODBUS RTU support with configurable MODBUS pages.
- Advanced SMS messaging (additional external modem required)
- Start & stop capability via SMS messaging
- 3 configurable maintenance alarms
- Compatible with a wide range of CAN engines, including tier 4 engine support
- Uses DSE Configuration Suite PC Software for simplified configuration
- Licence-free PC software
- IP65 rating (with supplied gasket) offers increased resistance to water ingress
- Modules can be integrated into building management systems (BMS) using MODBUS RTU

KEY BENEFITS

- Automatically transfers between mains (utility) and generator (DSE7320 MKII only) for convenience.
- Hours counter provides accurate information for monitoring and maintenance periods
- User-friendly set-up and button layout for ease of use
- Multiple parameters are monitored & displayed simultaneously for full visibility
- The module can be configured to suit a wide range of applications for user flexibility
- PLC editor allows user configurable functions to meet user specific application requirements.

SPECIFICATIONS

DC SUPPLY

CONTINUOUS VOLTAGE RATING
8 V to 35 V Continuous
5 V for upto 1 minute

CRANKING DROPOUTS

Able to survive 0 V for 100 ms, providing supply was at least 10 V before dropout and supply recovers to 5 V. This is achieved without the need for internal batteries. LEDs and backlight will not be maintained during cranking.

MAXIMUM OPERATING CURRENT

510 mA at 12 V, 240 mA at 24 V

MAXIMUM STANDBY CURRENT

330 mA at 12 V, 160 mA at 24 V

CHARGE FAIL/EXCITATION RANGE

0 V to 35 V

GENERATOR & MAINS (UTILITY) VOLTAGE RANGE

15 V to 415 V AC (Ph to N)
26 V to 719 V AC (Ph to Ph)

FREQUENCY RANGE

3.5 Hz to 75 Hz

MAGNETIC PICKUP

VOLTAGE RANGE
+/- 0.5 V to 70 V

FREQUENCY RANGE

10,000 Hz (max)

INPUTS

DIGITAL INPUTS A TO H

Negative switching

ANALOGUE INPUTS A & F

Configurable as:
Negative switching digital input
0 V to 10 V sensor
4 mA to 20 mA sensor
Resistive sensor

ANALOGUE INPUTS B, C, D & E

Configurable as:
Negative switching digital input
Resistive sensor

OUTPUTS

OUTPUT A & B (FUEL & START)

15 A DC at supply voltage

OUTPUTS C & D

8 A AC at 250 V AC (Volt-free)

AUXILIARY OUTPUTS E, F, G, H, I & J

2 A DC at supply voltage

DIMENSIONS

OVERALL

245 mm x 184 mm x 51 mm
9.6" x 7.2" x 2.0"

PANEL CUT-OUT

220 mm x 160 mm
8.7" x 6.3"

MAXIMUM PANEL THICKNESS

8 mm
0.3"

STORAGE TEMPERATURE RANGE

-40°C to +85°C
-40 °F to +185 °F

OPERATING TEMPERATURE RANGE

-30°C to +70°C
-22 °F to +158 °F

HEATED DISPLAY VARIANT

-40 °C to +70 °C
-40 °F to +158 °F

RELATED MATERIALS

TITLE

DSE7310 MKII & DSE7320 MKII Installation Instructions
DSE7310 MKII & DSE7320 MKII Operator Manual
DSE7310 MKII & DSE7320 MKII Configuration Suite PC Manual

PART NO.

053-181
057-253
057-243

DEEP SEA ELECTRONICS LTD

Highfield House, Hunmanby Industrial Estate, Hunmanby YO14 0PH
TELEPHONE +44 (0) 1723 890099
EMAIL sales@deepseaelectronics.com **WEBSITE** www.deepseaelectronics.com

DEEP SEA ELECTRONICS INC USA

3230 Williams Avenue, Rockford, IL 61101-2668 USA
TELEPHONE +1 (815) 316 8706
EMAIL usasales@deepseaelectronics.com **WEBSITE** www.deepseaelectronics.com

DSE7310/20 MKII

AUTO START & AUTO MAINS FAILURE CONTROL MODULES

The DSE7310 MKII is an Auto Start Control Module and the DSE7320 MKII is an Auto Mains (Utility) Failure Control Module suitable for a wide variety of single, diesel or gas, gen-set applications.

Monitoring an extensive number of engine parameters, the modules will display warnings, shutdown and engine status information on the back-lit LCD screen, illuminated LEDs, remote PC and via SMS text alerts (with external modem).

The DSE7320 MKII will also monitor the mains (utility) supply. The modules include USB, RS232 and RS485 ports as well as dedicated DSENet® terminals for system expansion.

Both modules are compatible with electronic (CAN) and non-electronic (magnetic pick-up/alternator sensing) engines and offer an extensive number of flexible inputs, outputs and extensive engine protections so the system can be easily adapted to meet the most demanding industry requirements.

The extensive list of features includes enhanced event and performance monitoring, remote communications & PLC functionality. Dual mutual standby is now available on both the DSE7310 MKII & DSE7320 MKII using RS232 or RS485 communications. This provides for a simpler and more convenient installation with more advanced features such as true engine hours balancing.

The modules can be easily configured using the DSE Configuration Suite PC software. Selected front panel editing is also available.

ENVIRONMENTAL TESTING STANDARDS

ELECTRO-MAGNETIC COMPATIBILITY

BS EN 61000-6-2
EMC Generic Immunity Standard for the Industrial Environment
BS EN 61000-6-4
EMC Generic Emission Standard for the Industrial Environment

ELECTRICAL SAFETY

BS EN 60950
Safety of Information Technology Equipment, including Electrical Business Equipment

TEMPERATURE

BS EN 60068-2-1
Ab/Ae Cold Test -30 °C
BS EN 60068-2-2
Bb/Be Dry Heat +70 °C

VIBRATION

BS EN 60068-2-6
Ten sweeps in each of three major axes
5 Hz to 8 Hz at +/-7.5 mm,
8 Hz to 500 Hz at 2 gn

HUMIDITY

BS EN 60068-2-30
Db Damp Heat Cyclic 20/55 °C
at 95% RH 48 Hours
BS EN 60068-2-78
Cab Damp Heat Static 40 °C
at 93% RH 48 Hours

SHOCK

BS EN 60068-2-27
Three shocks in each of three major axes
15 gn in 11 ms

DEGREES OF PROTECTION PROVIDED BY ENCLOSURES

BS EN 60529
IP65 - Front of module when installed into the control panel with the supplied sealing gasket.

COMPREHENSIVE FEATURE LIST TO SUIT A WIDE VARIETY OF GEN-SET APPLICATIONS

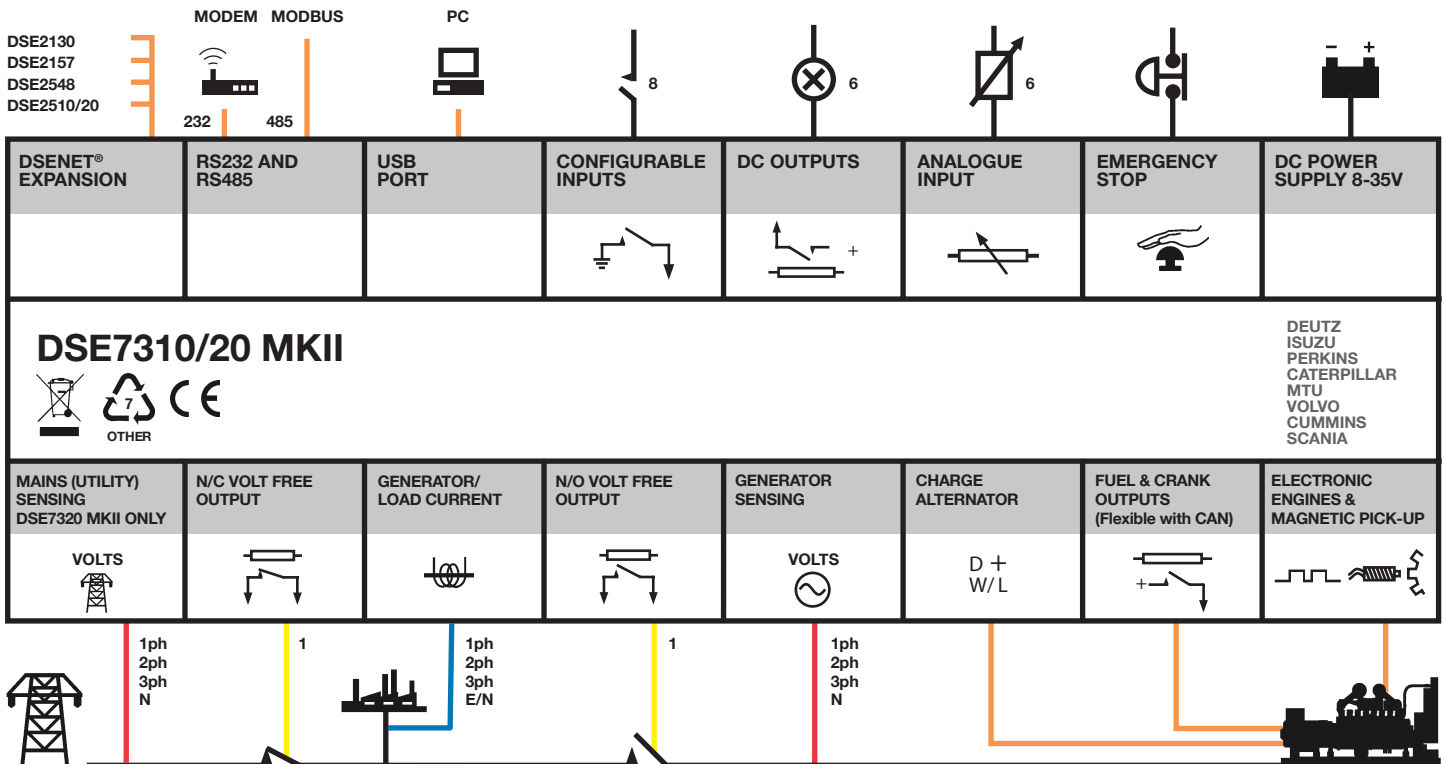

DIMENSIONAL DRAWINGS



TJ-4F-R-92DW6L

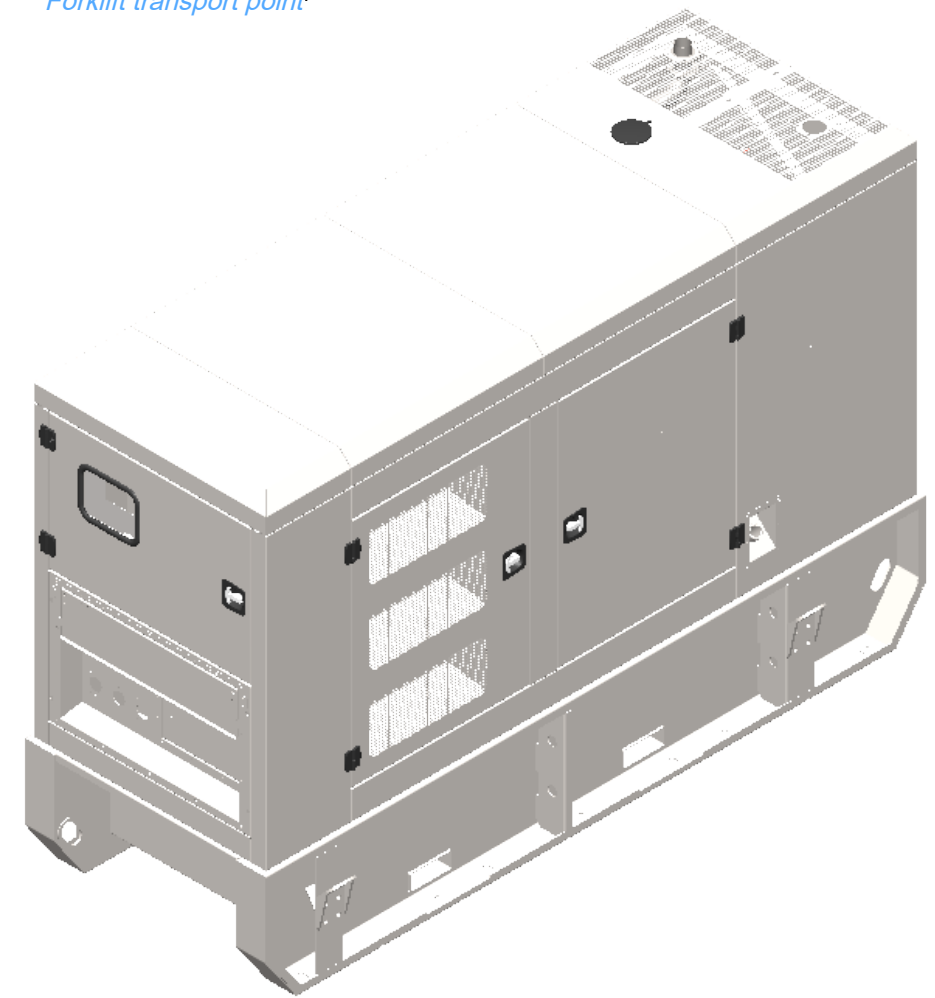
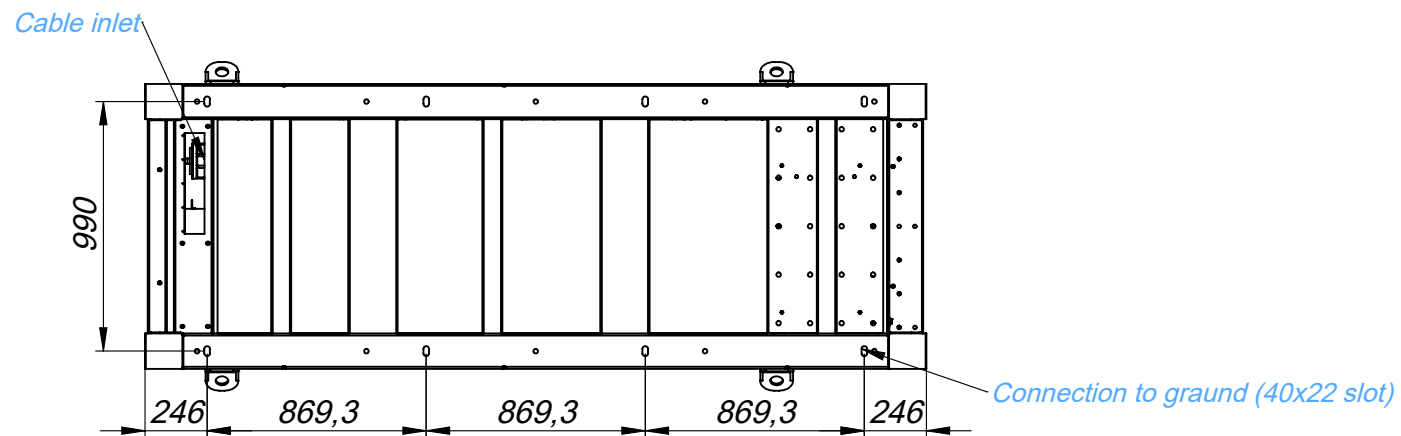
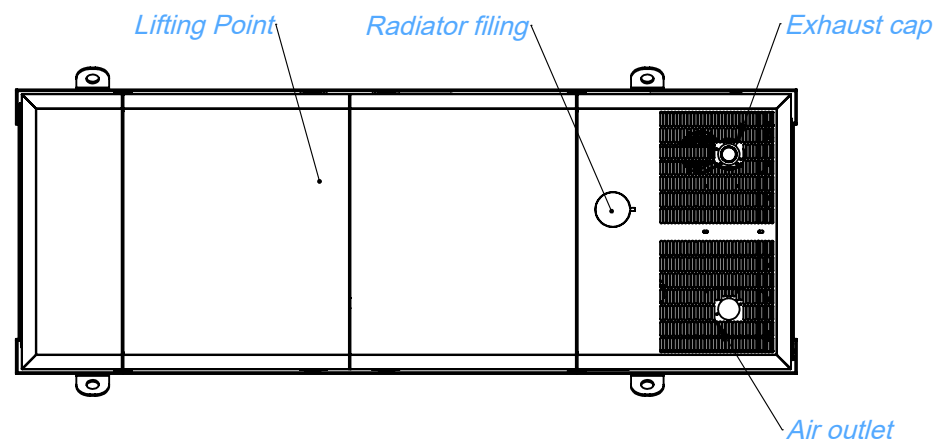
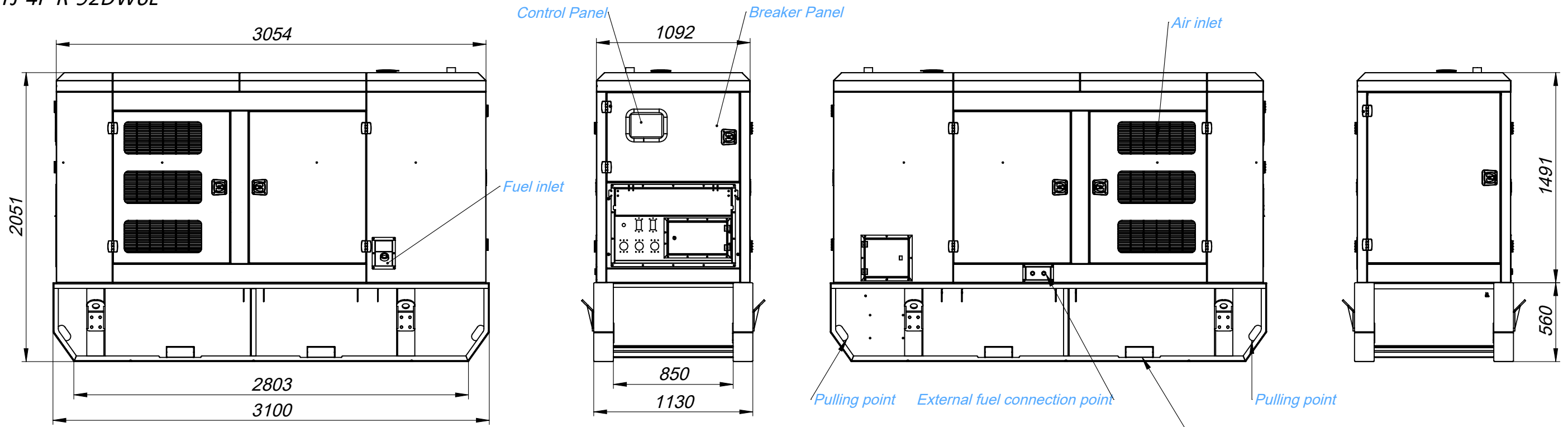

Please do not take measures on the drawings.

	Tolerances	Name	Date	Document No
	ISO 2768	Yasin Parlak	13-05-2022	SM-220577130
	1. Projection Method	Checked	-	Part Code
		Approval	-	-
* _ *	Paper Size	Scale	Order No	Rev. No
	A3	1:30	4021390-50-60	R01(G)
				Title
				Jeneratör Seti-Dizel-Kabinli-

CERTIFICATIONS



Certificate of Registration



This is to certify that the Quality Management System of
Teksan Jeneratör Elektrik Sanayi ve Ticaret A.Ş.

Yenidoğan Mahallesi, Edebalı Caddesi No:12 Sancaktepe , İstanbul , Turkey

(Central function listed above. See appendix for additional locations)

applicable to

Design, manufacture,testing, installation and after sales service of generator sets and trade, customs clearance, management and administrative activities, and associated production and services,utilizing the requirements of ISO10002 customer satisfaction

has been assessed and registered by NQA against the provisions of

ISO 9001:2015

This registration is subject to the company maintaining a quality management system, to the above standard, which will be monitored by NQA

Managing Director



Certificate No:	10942
ISO Approval Date:	20 March 2001
Reissued:	5 April 2022
Valid Until:	23 May 2025
EAC Code:	19,29,31

Certificate of Registration



This is to certify that the Management System of
Teksan Jeneratör Elektrik Sanayi ve Ticaret A.Ş.

Yenidoğan Mahallesi, Edebali Caddesi No:12 Sancaktepe , İstanbul , Turkey

applicable to

Design, manufacture, testing, installation and after sales service of generator sets and trade, customs clearance, management and administrative activities

has been assessed and registered by NQA against the provisions of

ISO 10002:2018 Quality management - Customer satisfaction- Guidelines for complaints handling in Organizations

This unaccredited registration is subject to the company maintaining a quality management system, to the above standard, which will be monitored by NQA

Managing Director

Certificate No:	10942-CS
ISO Approval Date:	23 February 2017
Reissued:	8 April 2022
Valid Until:	23 May 2025

Certificate of Registration



This is to certify that the Environmental Management System of
Teksan Jeneratör Elektrik Sanayi ve Ticaret A.Ş.

Yenidoğan Mahallesi, Edebali Caddesi No:12 Sancaktepe , İstanbul , Turkey

applicable to

Design, manufacture, testing, installation and after sales service of generator sets and trade, customs clearance, management and administrative activities and associated production and services

has been assessed and registered by NQA against the provisions of

ISO14001 : 2015

This registration is subject to the company maintaining an environmental management system, to the above standard, which will be monitored by NQA

A handwritten signature in black ink, appearing to read 'M. Yılmaz'.

Managing Director



Certificate No:	E980
ISO Approval Date:	17 November 2005
Reissued:	5 April 2022
Valid Until:	23 May 2025
EAC Code:	19,29,31



**UNITED STATES ENVIRONMENTAL PROTECTION AGENCY
2023 MODEL YEAR
CERTIFICATE OF CONFORMITY
WITH THE CLEAN AIR ACT**

**OFFICE OF TRANSPORTATION
AND AIR QUALITY
ANN ARBOR, MICHIGAN 48105**

Certificate Issued To: Hyundai Doosan Infracore Co., Ltd
(U.S. Manufacturer or Importer)

Certificate Number: PDICL03.4LED-009

Effective Date:
10/12/2022

Expiration Date:
12/31/2023

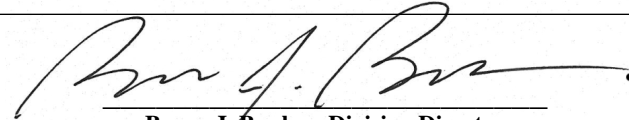
Byron J. Bunker, Division Director
Compliance Division

Issue Date:
10/12/2022

Revision Date:
N/A

Model Year: 2023
Manufacturer Type: Original Engine Manufacturer
Engine Family: PDICL03.4LED

Mobile/Stationary Indicator: Both
Emissions Power Category: 56<=kW<130
Fuel Type: Diesel
After Treatment Devices: Diesel Oxidation Catalyst, Ammonia Slip Catalyst, Selective Catalytic Reduction
Non-after Treatment Devices: Electronic Control

Pursuant to Section 111 and Section 213 of the Clean Air Act (42 U.S.C. sections 7411 and 7547) and 40 CFR Parts 60 and 1039, and subject to the terms and conditions prescribed in those provisions, this certificate of conformity is hereby issued with respect to the test engines which have been found to conform to applicable requirements and which represent the following engines, by engine family, more fully described in the documentation required by 40 CFR Parts 60 and 1039 and produced in the stated model year.

This certificate of conformity covers only those new compression-ignition engines which conform in all material respects to the design specifications that applied to those engines described in the documentation required by 40 CFR Parts 60 and 1039 and which are produced during the model year stated on this certificate of the said manufacturer, as defined in 40 CFR Parts 60 and 1039.

It is a term of this certificate that the manufacturer shall consent to all inspections described in 40 CFR 1068 and authorized in a warrant or court order. Failure to comply with the requirements of such a warrant or court order may lead to revocation or suspension of this certificate for reasons specified in 40 CFR Parts 60 and 1039. It is also a term of this certificate that this certificate may be revoked or suspended or rendered void *ab initio* for other reasons specified in 40 CFR Parts 60 and 1039.

This certificate does not cover engines sold, offered for sale, or introduced, or delivered for introduction, into commerce in the U.S. prior to the effective date of the certificate.

