

ENGINE DATASHEET



Frequency	Rpm	Gross Engine Output		Net Engine Output		Emission
		Standby / Prime kWm (ps)	Standby / Prime kWm (ps)	Standby / Prime kWm (ps)	Standby / Prime kWm (ps)	
50 Hz	1500	30(41) / 27(37)	28(38) / 25(34)			Stage V (DOC+DPF)
60 Hz	1800	42(57) / 38(51)	36(48) / 32(43)			Tier 4 Final (DOC only)



◆ General Engine Data

• Engine Type	In-line, 4-cycle
• Number of cylinders	3
• Displacement	1.794 liter
• Bore x Stroke	90 x 94 mm
• Compression ratio	17.0 : 1
• Firing order	1 - 2 - 3
• Aspiration	Turbocharged and air-to-air aftercooled
• Combustion System	Direct injection
• Rotation	Counter clockwise viewed from Flywheel
• Clutch	SAE#4 - 10" (SAE J620)
• Dry weight	238 kg (with aftertreatment) 303 kg (with powerpack)
• Valve System Type	Over head valve
• Number of Valves	Intake 2, exhaust 2 per cylinder Hydraulic Valve Lash Adjust

◆ Engineering Data

• Water flow	60 liters/min @1,500 rpm 70 liters/min @1,800 rpm
• Heat rejection	
- to coolant	6.5 kcal/sec @1,500 rpm 8.5 kcal/sec @1,800 rpm
- to CAC	0.6 kcal/sec @1,500 rpm 1.2 kcal/sec @1,800 rpm
• Air flow	1,850 liter/min @1,500 rpm 2,490 liter/min @1,800 rpm
• Exhaust gas temp	750 °C ↓ @1,500 rpm & 1800 rpm
• Max. permission restrictions	
- Intake system	3.0 kPa clean filter 6.5 kPa dirty filter
- Exhaust system	15 kPa max.

◆ Electrical System

• Alternator	12V x 110A / 12V x 140A
• Voltage regulator	Built-in type IC regulator
• Starting motor	12V x 2.5kW
• Battery voltage	12V
• Battery capacity	100 Ah, 750CCA (recommended)
• Starting Aid	Glow plug

◆ Cooling System

• Cooling method	Fresh water forced circulation
• Water capacity	3.1 liters (engine only) 8.4 liters (with powerpack)
• Water pump	Centrifugal type driven by belt
• Cooling fan	Blower type, Ø440 (ATB 52°C)
• Water temperature	110°C (max.)

◆ Fuel System

• Injection pump	Bosch Common-rail Pump
• Governor	Controlled by ECU
• Fuel filter	Full flow, cartridge type
• Used fuel	Diesel fuel oil
• Diesel consumption	222 g/kWh @1,500 rpm (g/kWh) 221 g/kWh @1,800 rpm

◆ Lubrication System

• Oil filter	Full flow, cartridge type
• Oil pan capacity	High level 6.3 liters Low level 2.8 liters
• Angularity limit	35 deg all around
• Lubrication oil	10W30/40 (API CK-4 / ACEA E6)
• Maximum oil temp	135°C at main oil gallery
• Lub oil pressure	Idle Speed : Min 100 kPa

◆ Engine Dimension

- Dimension (L×W×H) 728 × 574 × 730 mm (engine only)

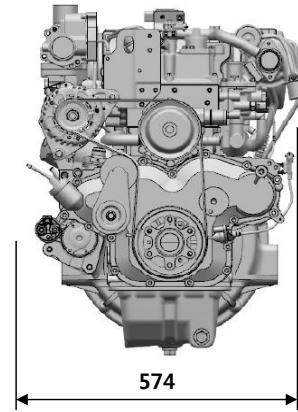
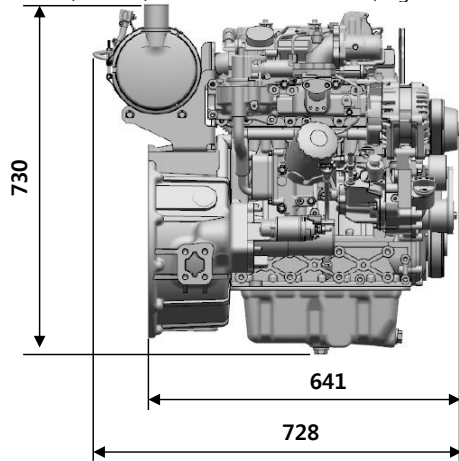

- Dimension (L×W×H) 1032 × 604 × 959 mm (with power pack)

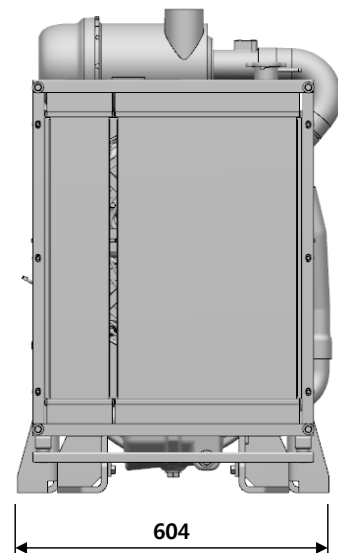
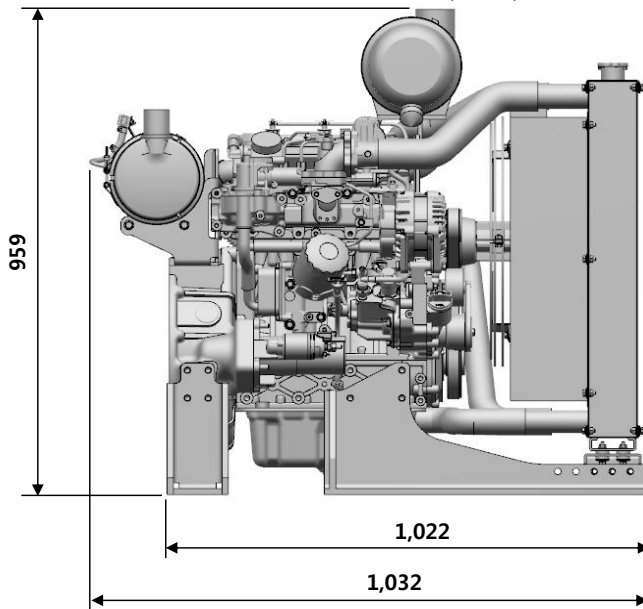

Ratings Definitions

The power ratings of Emergency Standby and Prime are in accordance with ISO 8528.

Fuel Stop power in accordance with ISO 3046.

Electric power (kWe) must be considered cooling fan loss, alternator efficiency, altitude derating and ambient temperature.

STANDBY POWER RATING is applicable for supplying emergency power for the duration of the utility power outage.

No overload capability is available for this rating. A standby rated engine should be sized for a maximum of an 80% average load factor and 200 hours of operation per year. This includes less than 25 hours per year at the Standby Power rating.

PRIME POWER RATING is available for an unlimited number of hours per year in variable load application. Variable load should not exceed a 70% average of the Prime Power rating during any operating period of 24 hours. The Total operating time at 100% Prime Power shall not exceed 500 hours per year. A 10% overload capability is available for a period of 1 hour withing a 12 hour period of operation. Total operating time at the 10% overload power shall not exceed 25 hours per year.

◆ Conversion Table

in. = mm x 0.0394	hp = PS x 0.98635	kW = 0.2388 kcal/s
PS = kW x 1.3596	lb = kg x 2.20462	lb/PS.h = g/kW.h x 0.00162
psi = kg/cm ² x 14.2233	lb/ft = N.m x 0.737	cfm = m ³ /min x 35.336
in ³ = lit. x 61.02	U.S. gal = lit. x 0.264	

Doosan Infracore Co., Ltd.

28th Floor, Doosan Tower, 275, Jangchungdan-ro, Jung-gu, Seoul, Republic of Korea (04563)

Tel : +82 2 3398 8893 / Fax : +82 2 3398 8898

E-mail : enginesales@doosan.com

Website : www.doosaninfracore.com

※Specifications are subject to change without prior notice.